

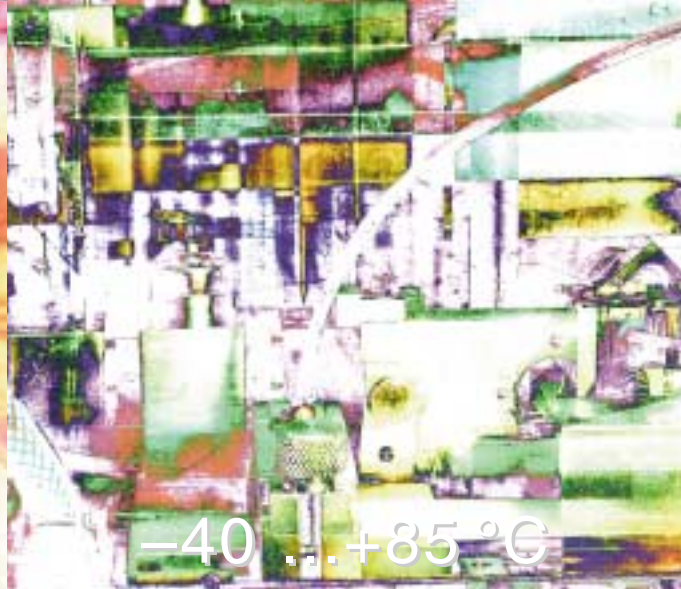

Sonnenschein Lithium Batteries

Technical
Brochure

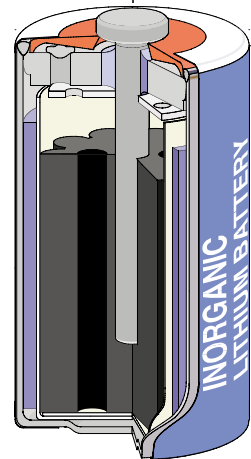

1 Basic Information

1.1 Sonnenschein Lithium

Sonnenschein Lithium was founded in 1984, with plant facilities at Büdingen near Frankfurt, Germany. The creation of the company was preceded by a transfer of know-how agreement with prestigious partner firms and several years of market experience. Today, the company is one of the leading manufacturers in the European market for lithium thionyl chloride batteries.

Research and Development has been a decisive factor in establishing the company's leadership position. Environment-friendly manufacturing processes, continuous improvement and constant enhancement of the battery system as well as the specialization in lithium batteries help to strengthen the competitive edge of Sonnenschein Lithium's customers in their respective markets and ensure the availability of reliable power supplies for their electronic products, today and in the future.

As one of the first battery manufacturers, Sonnenschein Lithium has obtained ISO 9001 certification of the quality management system in 1993 and ISO 14001 certification of the environmental management system in 1999.

Close co-operation with the customer during the design phase is part of the company's basic philosophy. Sonnenschein Lithium offers comprehensive support from experienced specialists, and is committed to securing its position as a market leader and a competent, reliable technology partner.

1.2 The Sonnenschein Lithium Battery

The scope of this Technical Brochure are inorganic lithium batteries of the Li/SOCl₂ system.

The Sonnenschein Lithium Battery is a power source that is suited to the requirements of the new generation in microelectronics. For example, CMOS memories as well as utility meters require a lightweight power source providing safe and reliable performance over a wide range of environmental conditions, for long periods of time.

The Sonnenschein Lithium Battery is a component that can be permanently connected to a circuit, in many cases for the lifetime of the equipment. Its major advantages are:

High cell voltage.

The battery has an open-circuit voltage of 3.67 V and an operating voltage of 3.60 V, which are considerably higher than in any other commercially available primary battery.

Wide temperature range.

The batteries are capable of operation in a wide temperature range normally from -55°C to +85°C. One series has an extended temperature range up to 130°C. See paragraph 2.10 for more details.

High energy density.

The electrochemical system exhibits the highest energy density of any available primary battery: up to 650 Wh/kg and 1280 Wh/dm³.

Superior shelf life and reliability.

The Sonnenschein Lithium Battery has an outstandingly long shelf life and reliability. Tests have shown that storage for ten years at room temperature results in a capacity loss of less than 1% per year.

Failure rates in memory back-up applications were found to be below 200 fit (fit: failures in time. 1 fit = 1 failure in 10⁹ component hours); this corresponds to 0.175% per year.

Safety.

The safety of the Sonnenschein Lithium Battery design has been proven by almost 20 years of experience in the market and more than 50 millions of batteries in the field with no reported incidents. The complete line of products is recognized and regularly supervised by Underwriters Laboratories.

Hermetically sealed case.

The hermetically sealed case is essential for the long shelf life and inherent safety of the devices in which the batteries are used. The cover is welded to the can. A glass-to-metal seal is used to insulate the positive terminal.

1.3 Comparison to Other Systems

The lithium thionyl chloride battery system is superior when it comes to long-term applications with demanding reliability, space, and energy requirements. **Figure 1-1** shows the output voltage over discharge capacity per unit volume for various lithium battery systems and alkaline batteries. The area under each discharge curve corresponds to the energy density of the respective battery system and thus gives an answer to the question: "How long will my product operate with battery system X if I can spare a certain space Y".

For reliable long-term operation under varying environmental conditions, a reliable sealing method is essential. A note on the sealing method of each system is given in the legend of figure 1-1.

Figure 1-1

Comparison of different battery systems. The curves represent typical best values of commercial cylindrical cells when discharged at 25°C with the 1000 hour rate. The area under the curves corresponds to the energy density listed below. The list also gives a note on the sealing method

1	Li/SOCl ₂	1280 Wh/dm ³	hermetically welded
2	Li/SO ₂	430 Wh/dm ³	hermetically welded
3	Li/CF _x	550 Wh/dm ³	crimped elastomer seal
4	Li/MnO ₂	580 Wh/dm ³	crimped elastomer seal or hermetically welded
5	Li/FeS ₂	450 Wh/dm ³	crimped elastomer seal
6	Alkaline	280 Wh/dm ³	crimped elastomer seal

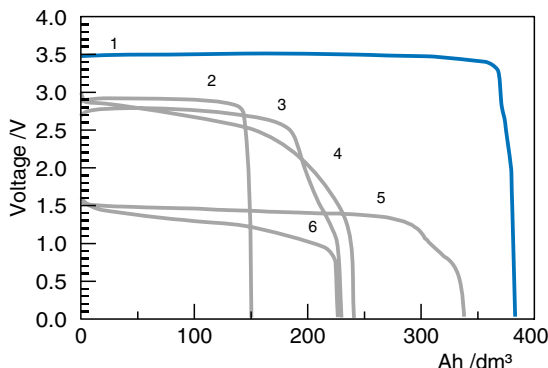

1.4 Customer Benefits

Sonnenschein Lithium has focused its ongoing efforts on promoting the understanding and further development of lithium batteries. This determination offers to the customer a number of decisive benefits such as:

- Access to over twenty years of experience in research and development, production and marketing
- Adaptability and reliability in meeting rapidly evolving customer needs
- Detailed technical support in terms of design and application - before, during and after the purchase
- Highly qualified experts available for support on short notice
- Customized production of single- and multi-cell batteries to meet specific requirements
- Reliable delivery, secured by contractual agreements and second sourcing.

For successful use of a battery, the co-operation between the supplier and the customer must commence at the earliest possible point: at times it is simply more economical to design a circuit for the characteristics of the best suitable energy supply, rather than having to forgo its advantages because it is too late for changes.

1.5 Applications

Because of their unique characteristics, Sonnenschein Lithium Batteries for many years have been used successfully for CMOS memory chips and a wide range of devices. Recently, there is a tendency towards the use of lithium batteries as autonomous pulse-operated power supplies - often in conjunction with highly demanding temperature profiles.

Following is a list of applications for Sonnenschein Lithium Batteries. **Table 1-2** lists the application oriented market segments and indicates the most suitable Sonnenschein Lithium Battery series.

Office Automation

RTC in personal computers, memory back-up, computer terminals, intelligent interfaces, point-of-sale terminals, word processors, intelligent typewriters, address

printers, envelope franking machines, cash points, cash registers, weighing machines, copy machines

Instrumentation

Vending Machines

Ticket vending machines, newspaper vending machines, cigarette vending machines, sweets vending machines, drink vending machines, parking meters, coin and bank note testing equipment

High End Consumer

Audio and video memory back-up and RTC, video games, gambling machines, SCUBA diving meters, altimeters, marine electronics, ski bindings, portable timing units for sport events, pigeon flight time recorders

Distress and Navigation

Radio distress beacons, emergency locating transmitters (ELT), distress beacons, rescue VHF/UHF radios, communication radios, global positioning system (GPS) equipment, mobile satellite communication links, avalanche rescue transmitters, life jacket emergency lights, maritime light buoys, deep sea hazard warning indicators

Offshore

Stationary sub-sea-level battery packs, platform emergency battery packs, diving bell life support, warning flash lights

Various

Industrial clocks, pulse-/event-counters, high voltage power line fault detectors, remote data logging and data acquisition systems, seismic measurement equipment, oceanographic measurement equipment, biotelemetry, telemetry equipment, weather balloon transmitters, automatic weather monitoring stations, compass illumination, caliper pigs for pipeline maintenance, oscilloscopes, medical instruments, gauges

Program Logic Control

Numeric and process control, heat meters, gas storage telemetry, computer integrated manufacturing (CIM), mobile data carriers /coded tags, temperature controllers, heat control installations

Telecommunication

Intelligent telephones, car phones, credit card phones, multiplexers, switchboards (PABX), mobile phone terminals, modems, ISDN terminals, telex and telefax machines, pagers, intercom systems

Utility Meters

Electricity meters, gas meters, heating cost allocation devices, water meters, calorimeters, automatic meter reading (AMR)

Military Electronics

Night vision equipment, cryptographs, radio frequency channel selectors, sonar buoys/pingers, underwater detectors, AT mines, advanced sea mines, smart AA fuzes, intelligent gun and mortar ammunition, missile systems, range finders, target acquisition equipment, portable flashlight beacons for runways

Security Systems

Door lockers, security and alarm systems, smoke and other sensors and detectors, burglar alarm systems

Market Segment	SL-300	SL-500	SL-700
Office Automation	++	-	o
Instrumentation	+	-	+
Program Logic Control	+	o	o
Telecommunication	++	-	o
Utility Meters	++	-	o
Military Electronics	o	-	o
Security Systems	o	-	+
Transponders	+	o	+
Automotive Electronics	+	o	+
High Temperature Systems	--	++	--

Table 1-2
List of market segments for Sonnenschein Lithium Batteries

The suitability is classified on a general basis and does not necessarily hold for each individual application:

- ++ preferred
- + recommended
- o possible
- less suited
- not recommended

2 Performance

Transponders

Identification transponder systems, mobile data carriers, road pricing systems, sub-sea transponders

Automotive Electronics

Mileage or kilometre counters, onboard computers, electronic monitoring, navigational equipment, airbag sensors and gas generators, belt straighteners, car radios, container temperature loggers, community traffic control systems, community vehicle locating systems, locating equipment for vehicles, traffic volume control, traffic chart recorders, taximeters, tyre pressure control systems

High Temperature Systems

Measurement-while-drilling (MWD), machine control, various industrial and automotive applications

2.1 General

This brochure deals with Sonnenschein Lithium Batteries. They belong to the thionyl chloride 3.6 Volt system and are manufactured in three basic series that differ by the process details of manufacture and are optimized according to the target application characterized by the following keywords.

Series Keyword

SL-300	standard use and stand-by
SL-500	extended temperature range
SL-700	enhanced start

The basic series are described in more detail at the end of this chapter and in the Sonnenschein Lithium Product Data Catalogue.

Performance data presented in this brochure are purely descriptive. They also depend on the given application and are not regarded as warranty of a quality or as an extension of the defects liability periods valid in accordance with our respective business conditions.

2.2 Voltage Response

Voltage Stability

It is a general feature of thionyl chloride batteries that voltage remains stable throughout their lives. The discharge curve typically has a rectangular shape, as can be seen from figure 2-1. A slight decline of the voltage that may occur during medium current discharge is due to an increase of internal resistance. Whenever discharge is interrupted voltage will return to its original value. This makes it possible to use virtually 100% of the battery's available capacity at a level well above 3 Volts. Please refer to paragraph 2.8 for more information on this subject.

Voltage Delay

When a battery is taken from the shelf and put on load for the first time, the cell voltage will drop from open circuit voltage (OCV) to an operating voltage that is a function of the discharge current. At low currents, the voltage level will stabilize instantly, see curve A in figure 2-2. However, at higher current values, there may be a transition period, during which the initial voltage drops below the plateau voltage before recovering. During this period, voltage may stay above the application cut-off voltage which is typically between 2.5 V and 3.0 V. Curve B in figure 2-2 represents this case. If current increases even more, voltage may drop below cut-off for a short time. The time before it recovers to the application cut-off is referred to as the delay time and the lowest value of voltage reached is called the transient minimum voltage (TMV), see curve C in fig. 2-2. The voltage delay phenomenon is due to passivation. It is related to the protective layer that forms on the anode surface and is described in more detail in chapter 3. Once a battery has been depassivated which means voltage has reached the normal plateau of operation it will not passivate again unless there is a subsequent long period on open circuit.

The degree of passivation is a function of storage time, current, temperature during storage, and mechanical aspects. Thus, passivation will usually grow with storage time and temperature. Depassivation can be effected by current flow as well as mechanical shocks, vibration, and temperature cycling. As a rule of thumb a current of

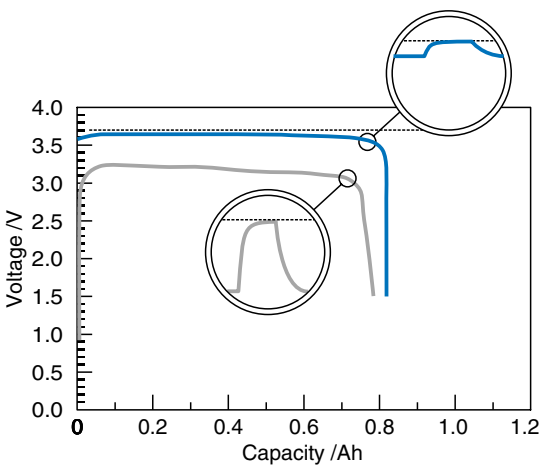

Figure 2-1
Discharge curves of 1/2AA size cells, type SL-350, at +25°C.

Grey curve:
180 Ω (30 hours)

Blue curve:
180 kΩ (4 years)

The circles indicate voltage recovery to 3.67 Volts (dashed line) whenever discharge is interrupted.

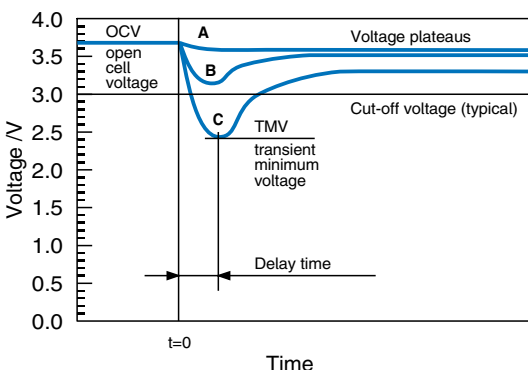

Figure 2-2
Transient voltage curves

- A low current:
no voltage delay
- B medium current:
voltage stays above cut-off
- C high current:
voltage drops momentarily below cut-off

2 $\mu\text{A}/\text{cm}^2$ of lithium anode surface area will prevent passivation and allow for immediate voltage response above typical application cut-off values. The same can be achieved by daily pulses corresponding to equivalent or slightly smaller average values.

SL-700 series

In general, the description in the previous paragraph holds for lithium thionyl chloride batteries of all three basic series. The SL-700 series, however, offers the advantage of an improved TMV and voltage delay time after storage. This is effected by a denser and more compact morphology of the protective layer on the lithium anode surface. **Figure 2-3** for example shows the transient voltage curves of one year old SL-350 and SL-750 batteries on a load of 330 Ω . While the voltage of SL-350 drops to 1.8 Volts, SL-750 stays above 3 Volts right from the start.

This advantage of the SL-700 series lasts for a maximum period of a few years on storage. It is impaired by storage at increased temperature levels and by continuous small current operation. As a result, the SL-300 series is usually preferred for long-term applications above 3 years of storage and operating life.

Figure 2-4, as an example, shows the development of TMV with storage time. The curves were obtained for $\frac{1}{2}$ AA size cells of the SL-300 and SL-700 series.

With respect to voltage delay, the SL-500 series behaves like SL-300.

End of life indication

Towards the end of life on long-term, continuous discharge, the initial resistance of the batteries will increase. As a result, voltage on load and particularly during current pulses, will gradually decline. This feature can be used for an end of life indication typically 3% before the operating life time comes to an end. The indication voltage is a function of the discharge current, the application cut-off voltage, the temperature range, and the required warning time. Both the accuracy of end of life indication and the length of the warning time can be increased by using current pulses and by confining indication to a narrow temperature range (**fig. 2-5**). Application support for the design of an effective end of life indication is offered by Sonnenschein Lithium engineers on a per case basis.

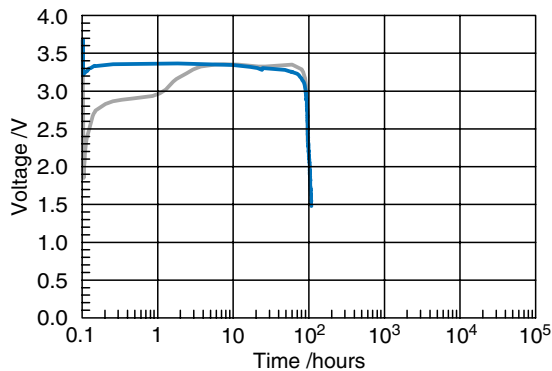

Figure 2-3
 Discharge of $\frac{1}{2}$ AA cells on 330 Ω after one year of storage at +25 $^{\circ}\text{C}$.
 Blue curve: SL-750
 Grey curve: SL-350

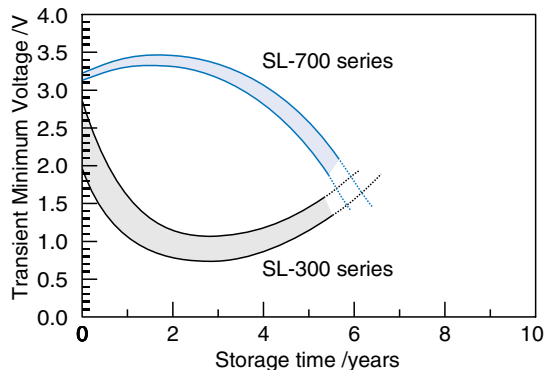

Figure 2-4
 Typical behaviour of voltage delay over storage time for two basic series. Discharge at 25 $^{\circ}\text{C}$ using the 100 hour rate (2 mA/cm^2)
 Data obtained with $\frac{1}{2}$ AA size on 330 Ω

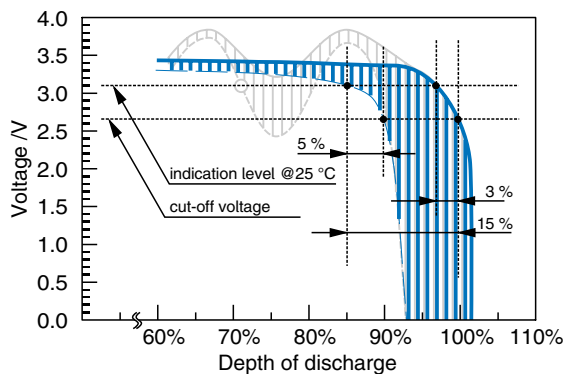

Figure 2-5
 Principles of End of Life Indication.

Solid blue curve:
 Discharge on continuous load at +25 $^{\circ}\text{C}$. End of life indication will occur approximately 3% before cut-off (based on total operation life).

Dashed blue curve:
 If test pulses are employed indication can be extended to approximately 15% of the total operation life if the cut-off voltage refers to the continuous load level and 5% if it refers to the pulse load level.

Grey curve:
 A seasonal temperature cycle can distort the discharge curve. End of life indication may occur at the grey circle for the first time leading to an early battery exchange. As a correction, indication can be suspended during temperature excursions. Alternatively, the limits or test pulse amplitude may be adjusted accordingly.

2.3 Discharge Current and Capacity

The available capacity generally depends on the discharge current or discharge time as indicated in **figure 2-6**. In the nominal range of discharge current or discharge time, the available capacity achieves its maximum value. At lower discharge currents, the self-discharge becomes significant because of the longer discharge time, and the available capacity is reduced accordingly. At higher discharge currents, effects caused by the speed of ion transport progressively reduce the discharge efficiency. The internal resistance increases and the available capacity is reduced. When opening a cell that was discharged with such a high current, it can be found that reaction products, that are deposited uniformly over the pore volume of the cathode during low and moderate current discharge, have now occupied and blocked the first few layers of cathode pores. It can thus be concluded that one reason for lower capacity at high current discharge is the reduction of accessible cathode pore volume.

In the literature, the current at which a battery delivers 76% of its saturation capacity is often referred to as its standard current. The battery will be overloaded if current is increased beyond this point.

2.4 Current Pulses

A typical pulse discharge pattern consists of a low continuous current drain with periodic or random short pulses at a higher current level. Generally, the duty cycle or ratio between on and off time ranges from 1:10 to 1:10 000 (**fig. 2-7**). The available capacity becomes now also a function of the duty cycle. For large duty cycles (1:10), it is close to the available capacity corresponding to the peak current. For small duty cycles (1:10 000), available capacity increases and tends to reach the value corresponding to the average current. **Figure 2-8** gives an example.

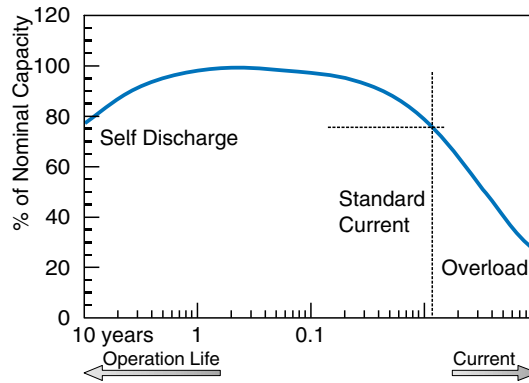

Figure 2-6
 Dependence of capacity on current.
 Self discharge increases with operation life. Overload occurs if current exceeds the standard current corresponding to 76% of the saturation capacity.

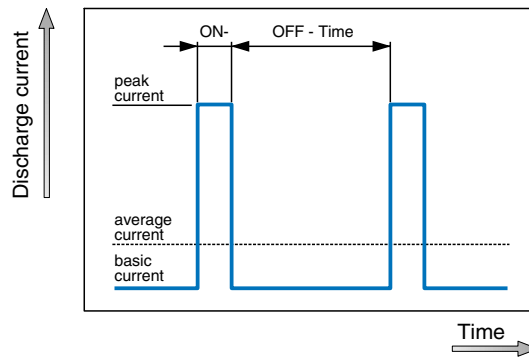

Figure 2-7
 Schematic pulse discharge pattern.
 Duty cycle means the ratio between ON- and OFF-time.

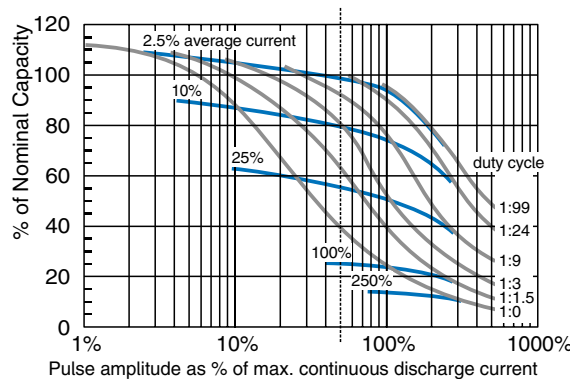

Figure 2-8
 Effect of pulse discharge on available capacity to 2 Volts at 25°C
 grey curves: constant duty cycle
 blue curves: constant average current as % of nominal current
 Data obtained with SL-780 batteries

2.5 Storage Life and Operating Life

While it has been found that it is practically impossible to apply standard methods of accelerated ageing to lithium thionyl chloride batteries in order to obtain reliable predictions of future performance, three methods can be used to collect data on long-term behaviour. These include actual long-term discharge, the extrapolation method, and the microcalorimeter method. The extrapolation method implies long-term storage or discharge combined with periodic determination of residual capacity. In the microcalorimeter method the heat output of cells on storage or on load is used to attempt a prediction of the loss that is due to self-discharge.

Actual discharge

Actual long-term discharge is the most accurate and reliable method. Unfortunately it is very time consuming. However, over the last decade, an extensive data basis has been collected by Sonnenschein Lithium to allow the prediction of expected storage and operating life times for a range of environmental conditions and required life times that covers all major application fields. **Figure 2-9** gives an example.

Two additional methods

The other two methods may be applied if results are needed quicker and it is not possible to refer to existing data obtained from actual long-term discharge. Both methods can accelerate the test duration to approximately 10% to 30% of the actual storage or operating time required for the application. When using the extrapolation method, it is important to carefully select the discharge parameters for the residual discharge. Current capability and anode passivation may change over the years and lead to erroneous results if discharge is too fast or takes place at a temperature that deviates from the optimum. **Figure 2-10** gives an example for the extrapolation method.

The microcalorimeter method is fairly expensive and sophisticated. It yields the heat output corresponding to the present status of a specimen. If this is extrapolated over the future operating time, an estimation of the integrated energy loss can be obtained. The test object, however, usually slightly changes its properties with time. As a consequence, careful calibration of the instrument and observation of the battery's heat output over several months are stringent prerequisites for meaningful predictions. It is also essential to observe a statistically relevant sample size. If substantial deviations of the data are found within the sample, this usually reflects the sensitivity of the method to various kinds of error possibilities rather than the battery performance itself. It should be noted here that results from the actual long-term discharge method usually do not deviate by more than $\pm 5\%$ within the sample while standard deviations of $\pm 50\%$ are typical for microcalorimeter studies conducted with normal carefulness.

Results

It is a conformable result of these methods that batteries of the SL-300 and SL-500 series have a capacity loss on storage of less than 0.5% per year while it is 2% for batteries of the SL-700 series. The self-discharge rate on operation as indicated above, is a function of the discharge current. Its value is 3 to 4% per year for an operating life of ten years.

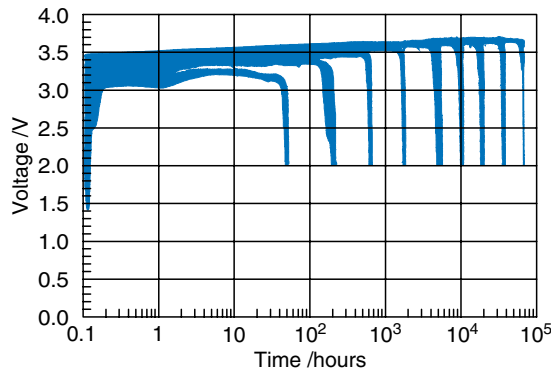

Figure 2-9
 Data basis for discharge of $\frac{1}{2}$ AA cells of type SL-350 at $+25^\circ\text{C}$. This diagram comprises a total of 85 discharge curves on constant load from $180\ \Omega$ (left) to $390\ \text{k}\Omega$ (right).

The load resistors were $180\ \Omega$, $560\ \Omega$, $1.8\ \text{k}\Omega$, $5.6\ \text{k}\Omega$, $18\ \text{k}\Omega$, $39\ \text{k}\Omega$, $82\ \text{k}\Omega$, $180\ \text{k}\Omega$, and $390\ \text{k}\Omega$ respectively. Batteries were taken from the shelf after one year of storage at room temperature. Depassivation takes place during the first per cent of the discharge.

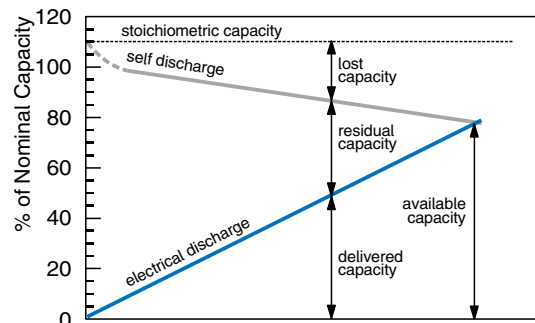

Figure 2-10
 Extrapolation method for operation life on continuous load without pulses.

2.6 Orientation

Depending on mechanical cell design and system properties, there is a certain dependence of available capacity on cell orientation during discharge. The effect is caused by the tendency of the electrolyte to move towards the void and inactive space of the battery if the orientation deviates from the preferred direction. The capillary effect of the cathode and separator pores acts against this tendency. As a result, the orientation effect is smaller for thin cathodes than it is for thick ones and is not even observable when discharge currents are very low or when batteries are moved during discharge.

The general capacity availability as a function of orientation can be summarized as follows:

- Throughout the nominal discharge current range, available capacity is practically unaffected if batteries are discharged upright or horizontally.
- At the low discharge current end or at infrequent, short, high current discharge pulses, capacities are practically unaffected if discharged upright or horizontally.
- At the high discharge current end, available capacity of the small and flat cells (AA, $\frac{2}{3}$ AA, $\frac{1}{2}$ AA, $\frac{1}{6}$ D, $\frac{1}{10}$ D, BEL) is virtually unaffected by orientation.
- At the high current end, available capacity of big cells (C, D, DD) is affected if the batteries are discharged upside down. Therefore this orientation should be avoided if possible.
- Available capacity of all cell sizes is not affected by orientation if they are moved occasionally during discharge.

2.7 Temperature Dependence

The nominal operating temperature of most basic series of Sonnenschein Lithium Batteries ranges from -40°C to $+85^{\circ}\text{C}$. Flat cells tend to expand somewhat at the high temperature end. They are limited to $+75^{\circ}\text{C}$ for this reason. The SL-500 series is designed so as to withstand temperatures up to 130°C . High temperature batteries for use up to 150°C are available upon request. At the low end of the temperature range, an extension to -55°C and even below is possible although storage down to -55°C and operation down to -40°C covers virtually all practical target applications. The freezing point of thionyl chloride at -105°C may be regarded as a limiting factor.

Generally, temperature has an influence on the ion mobility in the electrolyte and on the morphology of the protective layer. Thus, current capability increases with temperature but the effect is compensated to a certain extent by the increase of passivation during storage and self-discharge during operation.

Figure 2-11 shows the dependence of available capacity of SL-360 batteries on temperature. The nominal capacity of 2.3 Ah is marked by a black dot. It is found at room temperature using the nominal current which corresponds to the 1000 hour rate. The figure shows the range of capacities found for discharge down to an end voltage of 2.0 Volts. Three current levels are represented in the figure. At each current level, available capacity increases with temperature starting from the low temperature end to a maximum somewhere between 0°C and $+40^{\circ}\text{C}$. The maximum for medium currents is found at 25°C . Its position moves to higher tem-

peratures with increasing current. If temperature is increased beyond the maximum, self-discharge will determine the result.

A look at the three curves reveals an interesting feature: At the high temperature end, the medium current yields the highest capacity while both higher and lower currents lead to a lower efficiency. This can be explained by the competition between self-discharge and passivation, which counteract each other. A passivated anode providing medium current will suffer little from self-discharge. If the current is increased, however, passivation does not take place and the self-discharge due to the increased temperature reduces available capacity.

At low currents, passivation is high and self-discharge per unit time is very low. But if the current is decreased further, the operating times involved are so long that the integrated loss due to self-discharge increases again and results in a reduced available capacity.

While the preceding discussion may explain some of the more basic features of the thionyl chloride system, it does not necessarily stress the extraordinary and powerful long-term and high temperature performance of these batteries. **Figure 2-12** may help to demonstrate this excellence. It shows the results of a discharge test of ten batteries of type SL-550 ($\frac{1}{2}$ AA) at 150°C . On a load of $560\text{ k}\Omega$ corresponding to an average current of $6\ \mu\text{A}$, the batteries operated for more than 5 years yielding 65% of their nominal capacity.

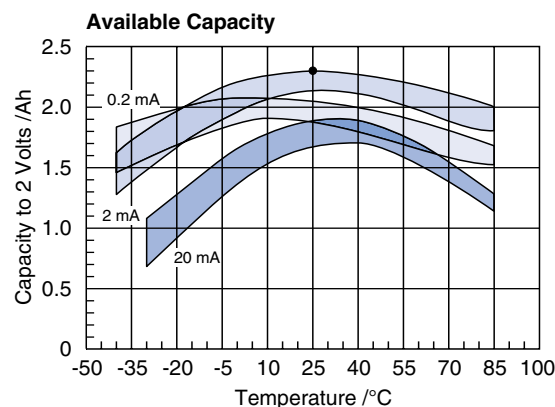

Figure 2-11
 Temperature dependence of available capacity for three different current levels.
 Size AA, type SL-360

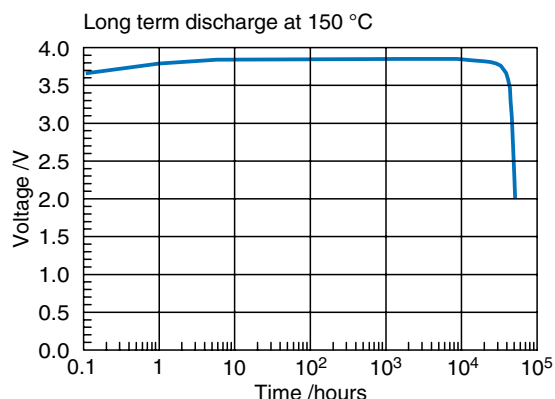

Figure 2-12
 Long-term discharge of $\frac{1}{2}$ AA size cells, type SL-550 at $+150^{\circ}\text{C}$ for more than 5 years on a continuous load of $560\text{ k}\Omega$ corresponding to a current of $6\ \mu\text{A}$

2.8 Environmental Conditions

Due to its reliable design, the Sonnenschein Lithium Battery is serviceable under extreme environmental conditions.

Altitude and Pressure

The sealing method and general properties of the battery allow storage and operation at any altitude from the earth's surface to deep space without degradation. In the opposite direction, pressure can be increased up to 20 atmospheres or more. Static force of up to 200 N on the positive terminal is allowable.

Vibration

The batteries can be subjected to normal vibration conditions during transport and operation. As a consequence, they can be used as a power source in any kind of transport system. Some types have even been proposed as a power source for electronic devices in car wheels.

Magnetic Properties

The can and cover are made from carefully nickel plated cold rolled steel and have the normal magnetic susceptibility of this material.

Humidity

As the cell voltage of lithium batteries exceeds the voltage needed for electrolysis of water molecules, they have to be protected from liquid water and condensation. A film of water across the battery terminals may not only lead to corrosion but also to external discharge. The Sonnenschein Lithium Battery will, however, not be affected by damp heat or humidity without condensation.

2.9 Internal Resistance

The internal resistance of a battery is derived by calculation from the voltage behaviour during pulse loads. Assuming that the same value is obtained if amplitude, duration, and frequency of pulses are changed, internal resistance can be used to predict the voltage response of the battery under arbitrary pulse loads. Unfortunately, it turns out that internal resistance of inorganic lithium batteries depends on numerous factors which include storage time, temperature, history, level of background current, depth of discharge and a few others. This makes it difficult to predict the battery's behaviour from one or even a few internal resistance values.

It is, however, important to develop a general understanding of the evolution of internal resistance with operating time in order to optimize the useful battery life.

Figure 2-13 shows the discharge curve (1) of a Sonnenschein Lithium Battery on a continuous load corresponding to approximately 10 $\mu\text{A}/\text{cm}^2$, superimposed with 6 pulses per hour of 10 mA/cm^2 for 0.5 s. The operating life is approximately 9 months. For 97% of the battery's life, the voltage U_9 on the basic load remains above 3.6 Volts.

Internal resistance is represented by curve (3). It was calculated from the voltage drop on application of the pulse load using the equation

$$R_i = \frac{\Delta U}{\Delta I} = \frac{U_c - U_p}{I_p - I_c}$$

with c = continuous discharge
 p = pulse load

Curve (2) shows the voltage U_p during pulses.

When discharge commences, the internal resistance drops from its initial value – corresponding to anode passivation – to a stationary plateau value.

It is only after 70% of the battery's life that the internal resistance rises again, indicating that the battery approaches its end of life. If the application requires pulses, battery voltage may drop below the required limit at this point. Making use of the fact that the electromotive force of the battery remains above 3.6 Volts until complete exhaustion, it is possible, however, with the aid of a suitable capacitor to extend operating life beyond this point if the required pulses are not too long. For additional details please refer to chapter 7.

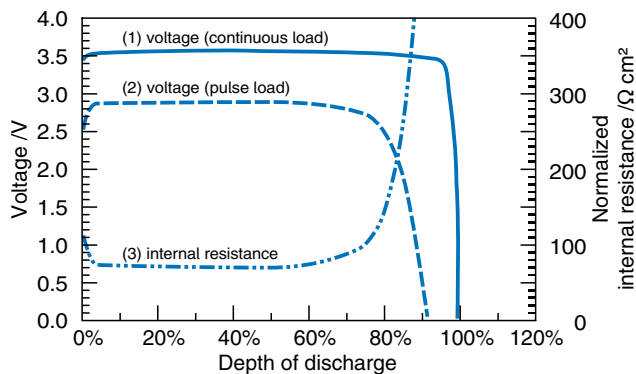

Figure 2-13

Schematic diagram showing the evolution of internal resistance during cell discharge at room temperature. The continuous current of approximately 10 $\mu\text{A}/\text{cm}^2$ is superimposed with 6 pulses per hour of 10 mA/cm^2 for 0.5 s. In order to make the diagram independent of battery size, the internal resistance on the secondary ordinate was multiplied by the electrode surface area.

3 Cell Design

2.10 Features and Attributes of the Basic Series

Series SL-300

Keywords: standard use and stand-by

- Excellent shelf life (10 years)
- Extremely low self-discharge (less than 0.5% per year on shelf)
- Suited for long-term use with low current
- For operation at low current levels with long stands
- Intermittent discharge with medium current level provided the average is not below the active current level
- Temperature range from -55°C to +85°C (flat batteries up to +75°C)

Series SL-500

Keyword: extended temperature range

- Extension of temperature range up to +130°C
- Somewhat smaller capacity
- Otherwise like series SL-300

Series SL-700

Keyword: enhanced start

- Major improvement of voltage delay at the start of discharge at medium current levels (TMV)
- Best results if used after no more than 3 years of storage
- Intermittent discharge at medium current levels
- Otherwise like series SL-300

Computer batteries

- Supplied with plastic outer case, cable and connector
- Classified by UL as "user-replaceable"
- Some versions with current and/or voltage limitation
- Some versions contain two or more cells.
- Otherwise like series SL-300
- Please request selection list for PC's.

3.1 Cell Components and Materials

Anode

The anode is made of a battery grade lithium foil, which is rolled against the inner surface of the cell can to provide a mechanically sound and reliable electrical connection.

Cathode

The cathode is made of highly porous Teflon-bonded carbon black whose electronic conductivity is needed for the charge transfer to take place. Thionyl chloride cathodic reduction is catalyzed by the cathode surface when a load is connected. The pores of the carbon cathode retain both the reactants and the products of this process.

Separator

The separator, between the anode and the cathode, prevents internal short-circuits and hence immediate discharge while enabling ions to move freely between the electrodes. It is made of non-woven glass, carefully selected for compatibility with the chemical system during prolonged storage and operation.

Electrolyte

The electrolyte is basically a solution of lithium aluminum tetrachloride in thionyl chloride, which retains its ionic conductivity over the entire temperature range. Thionyl chloride freezes only at -105°C. The electrolyte thus contributes essentially to the outstanding low temperature performance of the batteries. From the standpoint of the electrochemical reaction, thionyl chloride also forms the active depolarizer. The electrolyte is therefore often referred to as catholyte.

Current Collector

A metal current collector provides the electrical connection between the porous carbon cathode and the positive terminal of the battery. Different forms of current collector are used for small cells (½AA, ⅓AA, and AA), big cells (C, D, and DD), and flat cells (BEL, ⅒D, ⅓D).

Can and Cover

The cell can and cover are made of nickel-plated cold-rolled steel. The can is designed to withstand the mechanical stresses that would be encountered over the anticipated wide range of environmental service conditions.

3.2 Mechanical Design

Sonnenschein Lithium thionyl chloride batteries are manufactured in two distinct mechanical designs, the cylindrical bobbin type, and flat cells. These two designs differ in the ratio of height and diameter as well as in the way anode and cathode are arranged with respect to each other.

Bobbin Design

In the bobbin design (Fig. 3-1), the cathode is cylindrical in shape. The anode is rolled against the inner wall of the battery case. This offers several advantages from the standpoint of safety. In the event of an unintentional short-circuit the discharge currents cannot exceed a limit that prevents hazardous situations. The heat generated, primarily at the contact surface between the anode and cathode, can easily be dissipated to the outside. The

design leads to a safe battery that needs no additional rupture vent.

Flat Cells

In the flat cells (Fig. 3-2), the anode is pressed onto the bottom of the case, and the cathode, having the shape of a disk, is situated on top of the anode. The design has the same advantages with respect to intrinsic safety as that of the bobbin version.

Jelly-Roll Design

When the moderate rate capability of the bobbin type design is not sufficient, the so-called jelly-roll design may present a solution. In this type of cell, the anode and cathode material have the shape of long thin strips that are wound like a jelly-roll. This yields a larger electrode surface area and a greater current capability. A comparable standard of safety is achieved in this version by means of additional design measures, like a rupture vent and a fuse.

Hermetic Seal

Sonnenschein Lithium engineers have carefully designed the sealing between the positive (+) cell terminal and the cell cover, which has the same electric potential as the negative (-) terminal. Hermiticity is ensured by a glass-to-metal seal using the compression seal technology. In addition, the cell cover is welded to the cell can by a LASER beam welding process. In contrast to most systems using crimp seal techniques or polymer materials, the sealing and insulating system of Sonnenschein Lithium Batteries is not sensitive to temperature and humidity changes of any kind within the range of operating conditions. It is thus a major contributor to the excellent shelf and operating lives obtained.

Safety Vent

A safety vent is sometimes incorporated in hermetically sealed batteries in order to reduce the burst pressure of the cell case. This has not been found to be an advantage with Sonnenschein Lithium Batteries. The majority are therefore not vented. Under all conditions of use, internal pressure stays far below the burst pressure. However, under extreme conditions of abuse, like e.g. heating in fire or by forcing a large current through the cell, internal pressure may reach a critical value. Experience has proven that it is possible to avoid these conditions successfully. No incidence was reported from the field within more than 20 years of experience with this cell design. Obviously, a close and straightforward customer consultation is necessary to this end.

It should be noted that safety vents are compulsory for user-replaceable batteries and for spirally wound cells. In these cases, the draw-backs of a vent with respect to long-term reliability and cost effectiveness are acceptable. Sonnenschein Lithium is prepared to supply most battery types with a vent if required.

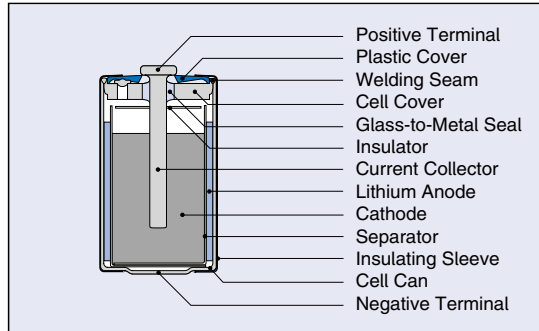

Figure 3-1
 Cross sectional view
 of a 1/2AA size cell
 (bobbin version)

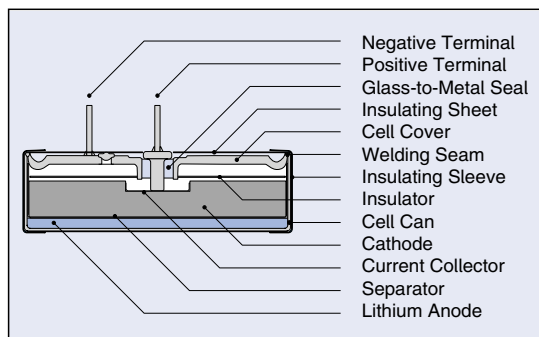
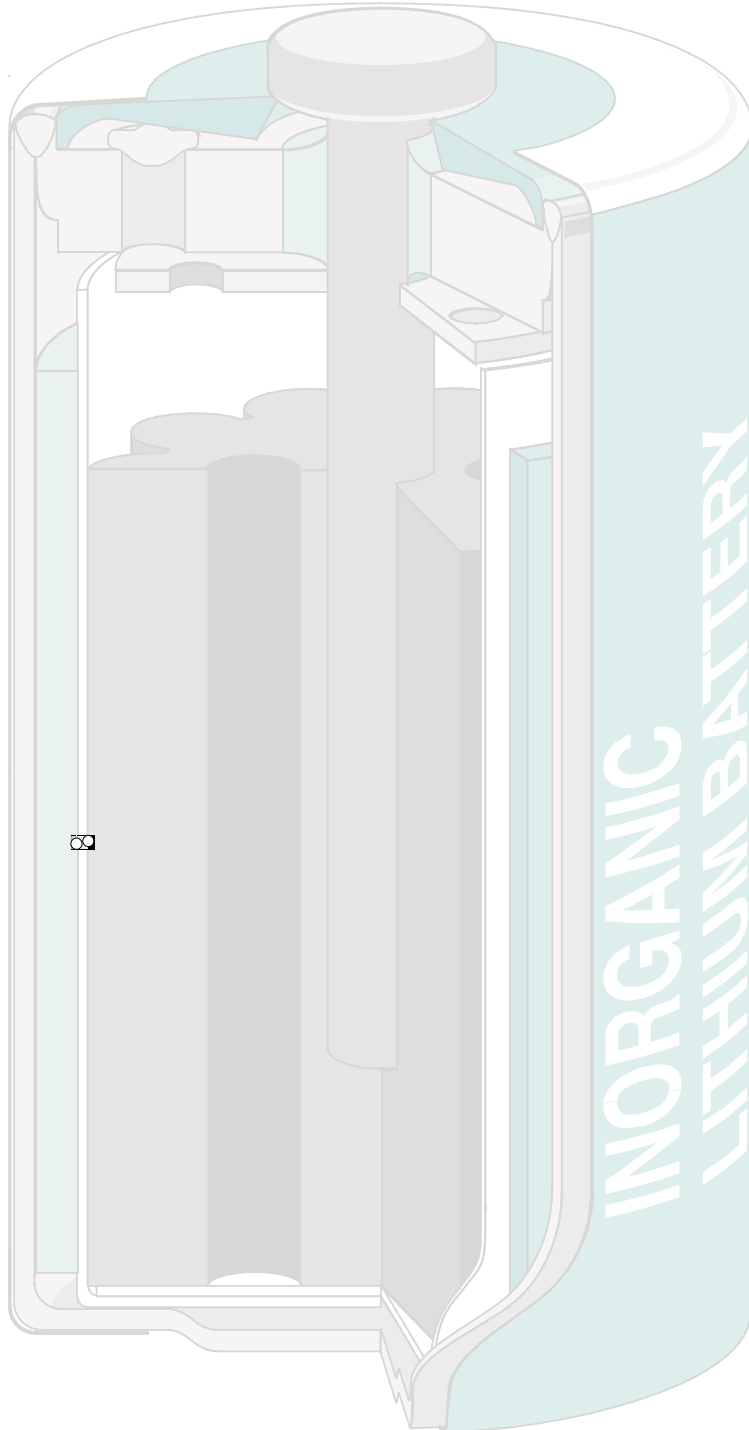
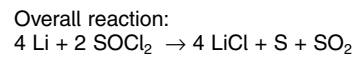
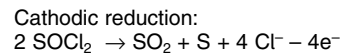
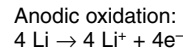

Figure 3-2
 Cross sectional view
 of a 1/6D size cell
 (flat cell)



3.3 Chemical Reaction and Protective Layer

The generally accepted overall discharge reaction during current flow is as follows:



Most of the sulphur dioxide formed during discharge is dissolved in the electrolyte by complex formation. This results in a low internal pressure before, during and after normal discharge.

A protective layer on the lithium surface is responsible for the excellent shelf life of lithium thionyl chloride batteries since it effectively prevents self-discharge. The layer basically consists of lithium chloride crystals that are formed as soon as the electrolyte comes into contact with the lithium anode during cell manufacture. As the layer grows, it prevents further reaction.

If an external load is connected to the battery, lithium ions formed on the anode surface can migrate through the layer which contains a sufficient number of vacancies needed for this process. If the current drain is increased the motion of the lithium ions will disturb the ionic lattice of the layer and eventually disrupt it or even break it up completely. At each level of this process, the conductivity of the layer is increased. The internal resistance thus decreases allowing for the voltage to reach a stable value. The process of adaptation usually takes some time and is responsible for the voltage delay.

The protective layer can be considered as consisting of two distinct parts. The one which is on the lithium surface is compact and thin. It is referred to as the solid electrolyte interface (SEI). On top of this layer there is a more porous layer of corrosion products which, to some extent, blocks the surface of the anode but does not take part in the electrochemical processes. It is often referred to as secondary porous layer (SPL).

The morphology, thickness, mechanical strength, and porosity of the layer influence the voltage behaviour when the battery is first loaded. The most severe voltage delay will be encountered for batteries stored for long periods at elevated temperature, discharged at low temperature (or during the cooling down period), and at high current density.

Figure 3-4 is a schematic overview of the reactions taking place in a lithium thionyl chloride cell.

Further reading:

Carbon cathode: E. Yeager et al., Proc. Power Sources Conf. 33, 115 (1988)

Protective layer: E. Peled in J.P. Gabano, Lithium Batteries, London 1983

Reduction of thionyl chloride: C. Schlaikjer, J. Power Sources 26, 161 (1989)

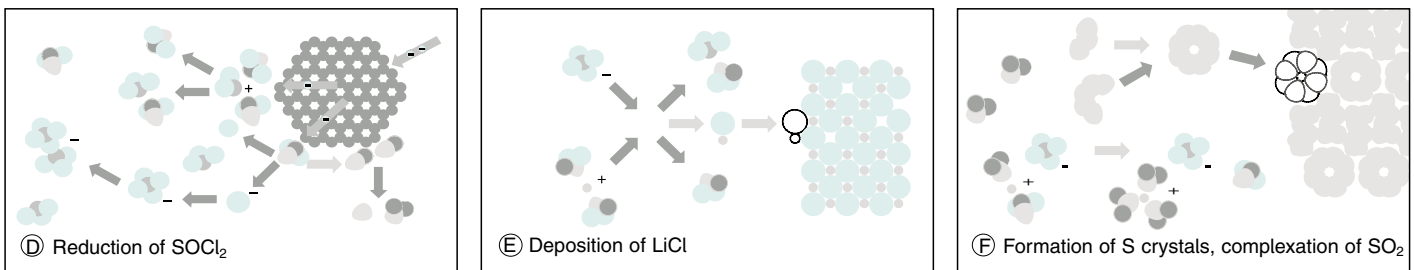
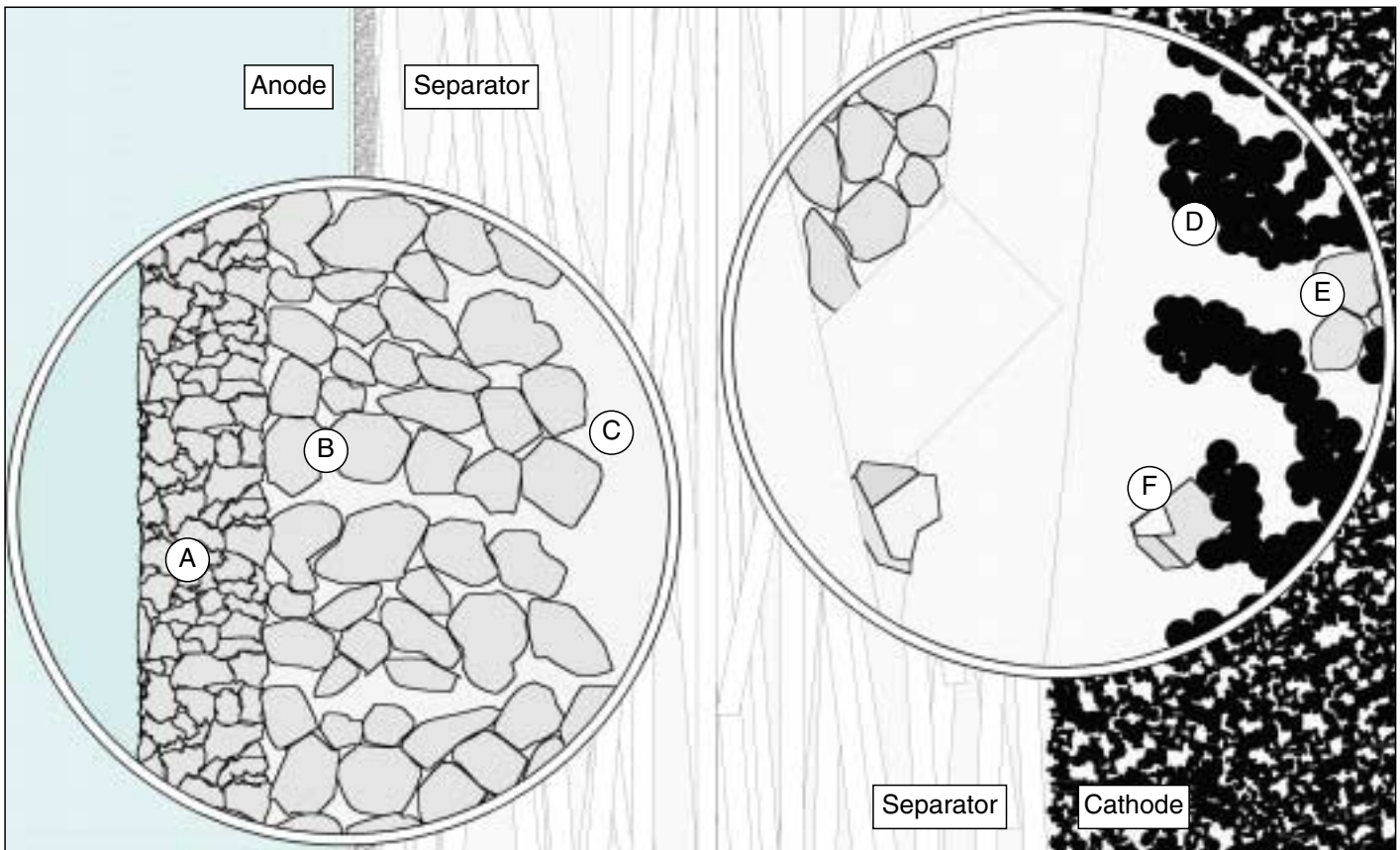
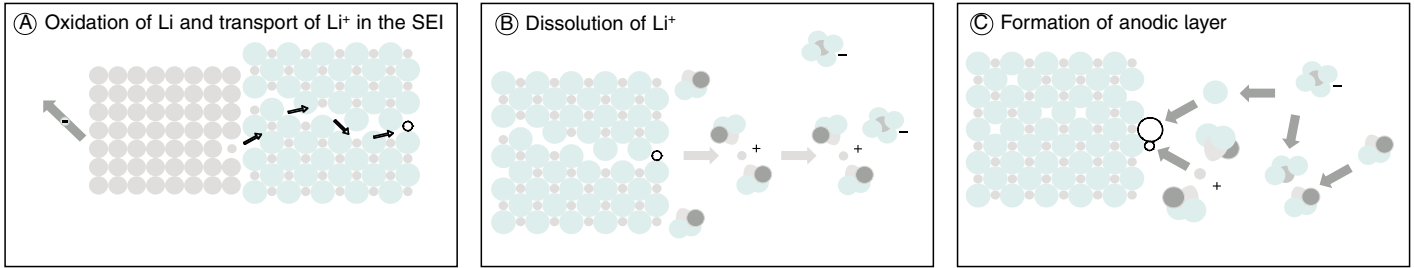
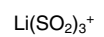

Figure 3-4
 Reaction mechanism of lithium thionyl chloride batteries. The circles are enlarged views of the anode surface (lower left) and cathode surface (upper right). The anode surface is covered with the SEI (solid electrolyte interface) and the SPL (secondary porous layer) on top of it. On the cathode and on the separator, both lithium chloride and sulfur crystals have formed as reaction products.

Atoms and Ions

- Al ●
- C ●
- Cl ●
- Li ●
- O ●
- S ●

- Cl⁻ ●
- Li⁺ ●



4 Safety

4.1 General

Each battery shall be used within the frame of intended use. This is defined as "the use of a product, process or service under conditions or for purposes in accordance with specifications and instructions provided by the supplier - including information for publicity purposes".

In Sonnenschein Lithium Batteries, safety requirements are considered at the design state, as well as throughout the production, transport, intended use, foreseeable misuse and disposal. The design of Sonnenschein Lithium Batteries has inherent safety features, due to:

- a) good heat dissipation
- b) relatively small surface area of the electrodes
- c) limited short-circuit current and thus limited temperature rise in the event of a short-circuit.

Due to these optimizations of the design, the batteries do not need a vent, which is a distinct difference to most of the other commercial lithium batteries.

4.2 Intended use tests

Following is a description of intended use and reasonably foreseeable misuse tests that are applicable to Sonnenschein Lithium Batteries. The test conditions are based on procedures which are published in the International Standard IEC 60086-4, second edition. IEC is the International Electrotechnical Commission in Geneva.

Discharge test

This test simulates the actual use of batteries. The limiting resistance value shall be specified for each battery type.

The undischarged battery is discharged, under limiting resistor R_1 for a test duration t_d

$$t_d = C_n \times R_1 / U_n$$

where

- t_d is the test duration;
- C_n is the nominal capacity;
- U_n is the nominal voltage;
- R_1 is a resistive load selected such that the average current draw is the same as the maximum discharge current specified in the Sonnenschein Lithium Product Data Catalogue.

The test shall be carried out at $20^\circ\text{C} \pm 2^\circ\text{C}$ until the battery is fully discharged and, in a separate test, at $60^\circ\text{C} \pm 2^\circ\text{C}$ until the battery is fully discharged.

Test batteries pass the test if there is no leakage, no venting, no explosion and no fire.

Vibration test

This test simulates vibration during transportation.

The test batteries shall be subjected to simple harmonic motion with an amplitude of 0.8 mm (1.6 mm total maximum excursion). The frequency shall be varied at a rate of 1 Hz/min between 10 Hz and 55 Hz, and return in no less than 90 min and no more than 100 min. The test battery shall be tested in three mutually perpendicular directions. If a test battery has only two axes of symmetry, it shall be tested in two directions perpendicular to each axis.

The test shall be conducted with undischarged batteries and with fully discharged batteries.

Test batteries pass the test if there is no weight loss, no distortion, no leakage, no venting, no explosion and no fire.

Mechanical shock test

This test simulates crash conditions or rough handling during transportation.

The test batteries shall be secured to the testing machine by means of a rigid mount which will support all mounting surfaces of each test battery. Each test battery shall be subjected to a total of three shocks of equal magnitude. The shocks shall be applied in each of three mutually perpendicular axes. Each shock shall be applied in a direction normal to a face of the test battery. For each shock, the test battery shall be accelerated in such a manner that during the first three milliseconds the minimum average acceleration is $75 g_n$. The peak acceleration shall be between $125 g_n$ and $175 g_n$.

The test shall be conducted with undischarged batteries and with fully discharged batteries.

The test shall be conducted using the batteries previously subjected to the vibration test.

Test batteries pass the test if there is no weight loss, no distortion, no leakage, no venting, no explosion and no fire.

Altitude test

This test simulates air transportation under low pressure conditions.

Test batteries shall be stored at a pressure of 11.6 kPa or less for at least 6 h and at a temperature of $20^\circ\text{C} \pm 2^\circ\text{C}$.

Test batteries pass the test if there is no leakage, no venting, no explosion and no fire.

Thermal shock test

This test assesses battery seal integrity under conditions of rapid temperature changes.

Test batteries shall be stored for 48 h at a temperature of $75^\circ\text{C} \pm 2^\circ\text{C}$, followed by storage for 6 h at a temperature of $-20^\circ\text{C} \pm 2^\circ\text{C}$, followed by storage for at least 24 h at ambient temperature. The maximum time for transfer to each temperature shall be 5 min.

The test shall be conducted using the batteries previously subjected to the altitude simulation test.

Test batteries pass the test if there is no leakage, no venting, no explosion and no fire.

4.3 Reasonably foreseeable misuse tests

In order to evaluate the safety limits of lithium batteries even under extreme abuse conditions, the tests listed below are provided.

Warning

These tests call for the use of procedures which may result in injury if adequate precautions are not taken. It has been assumed in the drafting of these tests that their execution is undertaken by appropriately qualified and experienced technicians using adequate protection.

The description of abuse tests in this brochure is for demonstration purposes only. During handling and appli-

cation of lithium batteries, abusive conditions must be avoided.

The range of intended use for Sonnenschein Lithium Batteries is specified in the data sheets (see also chapters 2 and 7 of this brochure). Any application or test requiring performance beyond the limits given in the data sheets must be approved by Sonnenschein Lithium.

Please refer to chapter 5 for abuse tests performed within the frame of the Underwriters Laboratories standard for safety as well as relevant military standards.

External short circuit test

This misuse may occur during handling of batteries.

The test batteries shall be stabilised at $55^{\circ}\text{C} \pm 2^{\circ}\text{C}$ and then subjected to a short-circuit condition with a total external resistance of less than 0.1Ω at $55^{\circ}\text{C} \pm 2^{\circ}\text{C}$. This short-circuit condition is continued for at least 1 h after the battery case temperature has returned to $55^{\circ}\text{C} \pm 2^{\circ}\text{C}$.

The test shall be conducted using the batteries previously subjected to the vibration test and shock test, and, separately, using the batteries previously subjected to the altitude test and the thermal shock test.

Test batteries pass the test if there is no explosion and no fire.

Charge test 1

This test simulates the condition when one battery in a set is reversed.

A test battery is connected in series with three undischarged additional batteries of the same type in such a way that the terminals of the test battery are connected in reverse.

A resistive load R_2 is connected in series to the above assembly of batteries where R_2 is selected such that the average current draw is the same as the maximum discharge current specified in the Sonnenschein Lithium Product Data Catalogue.

The circuit shall be closed, charging the test battery. The test shall be continued until the total voltage reaches 10% of the original open circuit voltage or for 24 h, whichever is longer.

The test shall be carried out at $20^{\circ}\text{C} \pm 2^{\circ}\text{C}$.

Test batteries pass the test if there is no explosion and no fire.

Charge test 2

This test simulates the condition when a battery is fitted within a device and is exposed to a reverse voltage from an external power supply, for example memory backup equipment with a defective diode.

Each test battery shall be subjected to a charging current of three times the maximum reverse (charging) current $I_{R \max}$ specified in the Sonnenschein Lithium Product Data Catalogue by connecting it in opposition to a DC power supply. Unless the power supply allows for setting the current, the specified charging current shall be obtained by connecting a resistor of the appropriate size and rating in series with the battery.

The test duration shall be calculated using the formula:

$$t_d = 2.5 \times C_n / (3 \times I_{R \max})$$

where

t_d is the test duration;

C_n is the nominal capacity;

$I_{R \max}$ is the maximum reverse (charging) current specified in the Sonnenschein Lithium Product Data Catalogue.

The test shall be carried out at $20^{\circ}\text{C} \pm 2^{\circ}\text{C}$.

Test batteries pass the test if there is no explosion and no fire.

Overdischarge test

This test simulates the condition when one discharged battery is connected in series with other undischarged batteries.

Each test battery shall be predischarged to 50% depth of discharge. It shall then be connected in series with three undischarged additional batteries of the same type.

A resistive load R_3 is connected in series to the above assembly of batteries where R_3 is selected such that the average current draw is the same as the maximum discharge current specified in the Sonnenschein Lithium Product Data Catalogue.

The test shall be carried out until the total voltage reaches 10% of the original open circuit voltage or for 24 h, whichever is longer.

The test shall be carried out at $20^{\circ}\text{C} \pm 2^{\circ}\text{C}$.

The test shall be repeated with fully predischarged test batteries.

Test batteries pass the test if there is no explosion and no fire.

Free fall test

This test simulates the situation when a battery is accidentally dropped.

Undischarged test batteries shall be dropped from a height of 1 m onto a concrete surface. Each test battery shall be dropped 6 times, a prismatic battery once on each of its 6 faces, a round battery twice in each of its three axes. The test batteries shall be stored for one hour afterwards.

The test shall be repeated with 25% predischarged test batteries.

Test batteries pass the test if there is no explosion and no fire.

Crush test

This test simulates the condition when a battery is exposed to forces encountered during household waste disposal, e.g. trash compaction.

A test battery shall be crushed between two flat surfaces. The force shall be applied by a vise or by a hydraulic ram with a 32 mm diameter piston. The crushing shall be continued until a pressure reading of 17 MPa is reached on the hydraulic ram, applied force approximately 13 kN. Once the maximum pressure has been obtained the pressure shall be released.

A cylindrical battery shall be crushed with its longitudinal axis parallel to the flat surfaces of the crushing apparatus. A prismatic battery shall be crushed by applying the force in the direction of one of the two axes perpendicular to its longitudinal axis, and, separately, by applying the force in the direction of the other one of these

two axes. A button/coin battery shall be crushed by applying the force on its flat surfaces.

Each test battery shall only be crushed once.

Test batteries pass the test if there is no explosion and no fire.

Thermal abuse test

This test simulates the condition when a battery is exposed to an extremely high temperature.

A test battery shall be placed in an oven and the temperature raised at a rate of 5°C/min to a temperature of 130°C ± 2°C at which the battery shall remain for 10 min.

Test batteries pass the test if there is no explosion and no fire.

4.4 Information for safety

This paragraph contains general safety information and is based on IEC publication 60086-4 which refers to lithium batteries of any kind, including those for consumer use.

Charge protection

When incorporating a primary lithium battery into a memory back-up circuit, a blocking diode and current limiting resistor or other protective devices shall be used to prevent the main power source from charging the battery (see Figure 7-1).

Parallel connection

Parallel connection should be avoided when designing battery compartments. However, parallel connection may be used in the assembly of battery packs as described in paragraph 7.3.

Safety precautions during handling

When used correctly, lithium batteries provide a safe and dependable source of power. However, if they are misused or abused, the following **possible results** may occur:

- leakage or
- venting or in extreme cases
- explosion and/or
- fire.

Do not insert batteries in reverse. Observe the + and – markings on battery and equipment.

When batteries are inserted in reverse they may be short-circuited or charged with the possible results mentioned above.

Do not short-circuit batteries

When the positive (+) and negative (–) terminals of a battery are connected directly with each other, the battery becomes short-circuited with the possible results mentioned above. One of the best ways to avoid short-circuiting is to store unused batteries in their original packaging.

Do not charge batteries

Attempting to charge a primary battery may cause internal gas and/or heat generation with the possible results mentioned above.

Do not force discharge batteries

When batteries are force discharged by means of an external power source, the voltage of the battery will be forced below its design capability with the possible results mentioned above.

Do not mix batteries

When replacing batteries, replace all of them at the same time with new batteries of the same brand and type. Otherwise some batteries may be charged due to a difference of cell voltage or overdischarged due to a difference of capacity with the possible results mentioned above.

Do not leave discharged batteries in equipment

Although Sonnenschein Lithium Batteries are most highly leak resistant, a battery that has been exhausted may be more prone to leak than one that is unused.

Do not overheat batteries

When a battery is overheated, electrolyte may be released and separators may deteriorate with the possible results mentioned above.

Do not weld or solder directly to batteries

The heat from welding or soldering directly to a battery may cause the lithium to melt with the possible results mentioned above.

Do not open batteries

When a battery cell is opened the components may cause personal injury or fire.

Do not deform batteries

Lithium batteries should not be crushed, punctured, or otherwise mutilated because this may lead to the possible results mentioned above.

Do not dispose of batteries in fire

When batteries are disposed of in fire the possible results mentioned above may occur. Do not incinerate batteries except for approved disposal in a controlled incinerator.

Do not expose contents to water

When the container of a lithium battery is damaged, lithium metal may be exposed. This may lead to the formation of hydrogen gas with the possible results mentioned above.

Keep batteries out of the reach of children

Especially keep swallowable batteries out of the reach of children. In case of ingestion of a cell or battery, seek medical assistance promptly.

5 Conformity with Standards

Sonnenschein Lithium
Technical Brochure

Sonnenschein Lithium Inorganic Batteries meet relevant standards like UL 1642 (Underwriters Laboratories), EN 50014 (explosive atmospheres) and military standards as well as several other application oriented ones like e.g. standards for safety and alarm equipment, standards for utility meters, and others. While some of these standards do include performance requirements for specific applications, the majority of them deals only with safety aspects and environmental conditions during storage, transport and use. No general standards exist for electrical performance of most inorganic lithium batteries. If reference is made to designations listed in ANSI C 18.1 (e.g. size AA) or to designations listed in IEC 60086, parts 1 and 2 (e.g. size R6) this pertains only to the size of the battery, not to its performance.

Sonnenschein Lithium Batteries are submitted for qualification according to the requirements of the market. Sonnenschein Lithium engineers offer their support whenever conformity of a specific battery with one of the standards mentioned below or with other standards needs to be established.

Test Designation	Test Method	Requirements
Short-Circuit	At +23°C and +60°C	NF, NE, NO
Abnormal Charging	Batteries connected in opposition to a dc-power supply. Initial current 3 times the maximum reverse current as given in the individual data sheets. Time equivalent to 2.5 times nominal capacity.	NF, NE, (R)
Forced-Discharge	Completely discharged battery in series with fresh batteries of the same kind	NF, NE, (M)
Crush	Pressure 17.2 MPa between 2 flat surfaces	NF, NE, (R)
Impact	A 9.1 kg weight dropped from 0.61 m on the battery, with a 15.8 mm diameter bar placed across the center of the battery	NF, NE, (R)
Shock	3 shocks per battery, average of 75 g during initial 3 ms, peak acceleration between 125 g and 175 g	NF, NE, NL, NV
Vibration	Simple harmonic motion, amplitude 0.8 mm (1.6 mm total excursion), 10 to 55 Hz, 1 Hz per min, 1 cycle (90 min)	NF, NE
Heating	Heat to 150°C and hold for 10 min	NF, NE, (R)
Temperature Cycling	10 cycles between +70°C and -40°C, 5 days total duration.	NF, NE, NL, NV
Low Pressure	6 hours at a pressure of 11.6 kPa	NF, NE, NL, NV
Tests for user-replaceable batteries	Fire exposure, flaming particles, projectile, explosion	NF, NE within specified limits.

Table 5-1

Safety tests covered by UL standard No. 1642 (revision 1999)

Abbreviations:

NF: no fire, NE: no explosion, NL: no leaking, NO: no overheating (150°C), NV: no venting, (R): if requirements are not met, application is to be restricted, (M): applicable only to cells intended to be used in multicell applications such as battery packs.

5.1 Underwriters Laboratories

Underwriters Laboratories Inc. (UL) is a non-profit organization whose objective is to set standards for product safety and supervise compliance with these standards by manufacturers of components or equipment.

Sonnenschein Lithium Batteries comply with the UL-standards as described here and in the relevant product data sheets. The following UL documentation refers to these batteries.

UL Standard for Safety	No.1642, Lithium Batteries
Component Category No.	BBCV2
File No.	MH12827

The safety tests covered by this standard are summarized in **table 5-1**. The standard also describes minimum requirements for casing, marking, protection circuits against abnormal charging and a few other subjects.

Protection against charging

Whenever lithium batteries are not the single power source in a circuit the following measures recommended by Underwriters Laboratories are relevant. The cells should not be connected in series with an electrical power source that would increase the forward current through the cells. The circuit for these cells shall include one of the following (please refer to paragraph 7.1 for a circuit diagram):

A. Two suitable diodes or the equivalent in series with the cells to prevent any reverse (charging) current. The second diode is used to provide protection in the event that one should fail. Quality control, or equivalent procedures, shall be established by the device manufacturer to ensure the diode polarity is correct for each unit, or

B. A blocking diode or the equivalent to prevent any reverse (charging) current and a resistor to limit current in case of a diode failure. The resistor should be sized to limit the reverse (charging) current to the maximum values given in the Sonnenschein Lithium Product Data Catalogue.

It should be noted here that the resistor R should be dimensioned such that $I = U_n / R$ does not exceed the given maximum values, U_n being the nominal voltage of the battery.

Battery Replacement

Lithium batteries of this category are technician-replaceable unless it is noted in the data sheets or in the UL component listing that a battery is user-replaceable.

A technician-replaceable battery is intended for use in a product in which service and replacement of the battery will be done only by a person who has been trained to service and repair the product. A battery that is intended for use in a product in which service and replacement of the battery may be done by the user will be categorized as user-replaceable.

With respect to user-replaceable lithium batteries of any chemical system, UL requires several procedures to ensure that important safety information reaches the end user.

The packaging for a user-replaceable battery shall be marked with the word "CAUTION" and the following or equivalent statements: "Risk of fire and burns. Do not recharge, disassemble, heat above 100°C, or incinerate. Keep battery out of reach of children and in original package until ready to use. Dispose of used batteries promptly."

The end product with a user-replaceable lithium battery shall be permanently marked adjacent to the battery:
"Replace battery with (battery manufacturer's name or end product manufacturer's name, part number) only. Use of another battery may present a risk of fire or explosion. See owner's manual for instructions." or "See operating or maintenance instructions for type of battery to be used."

The operating or maintenance instructions shall provide the user with complete instructions as to how to replace and dispose of a used battery. This information shall include the following:

- a) A warning notice stating the following or the equivalent: "CAUTION - The battery used in this device may present a risk of fire or chemical burn if mistreated. Do not recharge, disassemble, heat above 100°C, or incinerate. Replace battery with (battery manufacturer's name or end product manufacturer's name and part number) only. Use of another battery may present a risk of fire or explosion."
- b) Complete instructions as to how to replace the battery ending with the statement: "Dispose of used battery promptly. Keep away from children. Do not disassemble and do not dispose of in fire."

5.2 Explosive atmospheres

Requirements for batteries to be used in electrical apparatus for potentially explosive atmospheres are published in the European standard EN 50014. Sonnenschein Lithium can support manufacturers of such apparatus by providing temperature and current data of Sonnenschein Lithium Batteries during short circuit at 40 °C and 70 °C. Most Sonnenschein Lithium Batteries comply with temperature class T4 of this standard, which means they can be used in apparatus for potentially explosive atmospheres with an ambient temperature of up to +70 °C. Please contact Sonnenschein Lithium for more information on this subject.

5.3 Military standards

Because of their outstanding features with respect to environmental conditions of storage and use, lithium thionyl chloride batteries have found the interest of military users.

A special product - a reserve type cell - was developed by Sonnenschein Lithium for applications with a short or medium operating period after extremely long storage. Storage times of more than 8 years at +70 °C (!) have been achieved with this type of battery with no degradation of activation time and operating life. This product as well as several other batteries of the Sonnenschein Lithium basic series have passed environmental and safety tests described in the following military standards:

MIL-B-49461 (ER)	USA	Military specification for non-rechargeable lithium thionyl chloride batteries
MIL-STD-202	USA	Military standard: Test methods for electronic and electrical component parts
MIL-STD-331	USA	Military standard: Fuze and fuze components, Environmental and performance tests for
MIL-STD-810	USA	Military standard: Environmental test methods and engineering guidelines
VG 96915	GER	Defence material standard non-rechargeable batteries

Tests described in these standards and passed by Sonnenschein Lithium Batteries include the subjects and major test conditions summarized in **table 5-2**. Complete test descriptions and results are available upon request.

Test Designation	Test Method	Requirements
Environmental Tests		
Transport vibration	MIL-B-49461 (ER) para. 4.8.6	ND
Flight vibration	MIL-STD-810, test 514.2	ND
Drop	MIL-B-49461 (ER) para. 4.8.3	ND
Mechanical shock	MIL-B-49461 (ER) para. 4.8.5	ND
Temperature cycling	MIL-STD-331, test 113.1	ND
Altitude	MIL-B-49461 (ER) para. 4.8.7	ND
Safety Tests		
Short-circuit at +25 °C	MIL-B-49461 (ER) para. 4.8.10	NF, NE
Leakage	MIL-B-49461 (ER) para. 4.8.13	NL
Forced discharge	MIL-B-49461 (ER) para. 4.8.13.1	NV
Incineration	MIL-B-49461 (ER) para. 4.8.20	NE
Safety feature	MIL-B-49461 (ER) para. 4.8.10	FS

Table 5-2

Military standard tests passed by Sonnenschein Lithium Inorganic Batteries

Abbreviations: ND: no degradation, NF: no fire, NE: no explosion,
NL: no leakage, NV: no venting, FS: function of safety feature

6 Quality and Reliability

6.1 Corporate policy

Sonnenschein Lithium's corporate policy includes quality and environmental aspects as well as those of occupational and material safety.

Our objectives

- Long term corporate goals

The objective of our company is the development, manufacture and marketing of lithium batteries which are considered as number one products by our customers. Through high efficiency and continual improvement of our work we ensure the growth of our company, in the interest of our customers, our employees and our shareholders.

This includes the continual improvement in such areas as environment protection, quality and safety.

- Importance of quality

By quality we understand the fulfilment of the requirements and expectations of our customers, suppliers and employees. The management and employees of Sonnenschein Lithium consider the quality of their products and services to be decisive for their continuing success.

- Environment and safety

Our company employs procedures that eliminate environment and safety risks for its employees, neighbourhood and product users.

The fulfilment of legal and other regulations is considered as a minimum requirement.

- Responsibility of management and employees

Every employee takes on his share of responsibility in the process of continual improvement in our company. He orients his daily work by the expectations of his internal and external customers. This includes the demands of economy, environment protection and safety. Every individual sets an example while achieving the quality and environmental targets. Leadership personnel supports and promotes measures and attitudes that are necessary to achieve the targets.

Our activities

- Conduct periodic surveys of customer satisfaction
- Systematically analyze and improve the relations between internal customers and suppliers
- Include external suppliers in the process of continual improvement on a basis of partnership
- Provide and implement all required quality and environmental management procedures
- Periodically obtain ISO 9001 and ISO 14001 recertification
- Define annually measurable quality and environmental targets
- Review the management system on an annual basis
- Determine the requirements for environment protection and occupational safety
- Continually upgrade the qualifications of all employees by training and instruction
- Establish improvement teams
- Activate the suggestion system
- Implement suggestions for quality improvement
- Assess the environment, safety and quality related effects when introducing new products or processes.

- Advise customers on product properties with respect to the application, handling and disposal.
- Provide the technical documentation considering the effective regulations and laws.
- Provide all information to interested parties that is necessary to understand the environmental effects of products and manufacturing procedures.
- Periodically review and improve procedures for the prevention of incidents and accidents.

6.2 Certified Management System

Sonnenschein Lithium holds a certificate verifying that its quality and environmental management system fulfills the requirements of the standards ISO 9001 and ISO 14001. The audit of the quality management system was first performed in 1993. The audit of the environmental management system was first performed in 1999.



Figure 6-1
Management system certified by DQS

6.3 Calibration and inspection equipment

Measurements that can have an influence on product quality are carried out using calibrated equipment having a known valid relationship to nationally recognized standards.

Sonnenschein Lithium engineers identify those process steps that need special inspection methods and develop the equipment needed to ensure product quality under all circumstances.

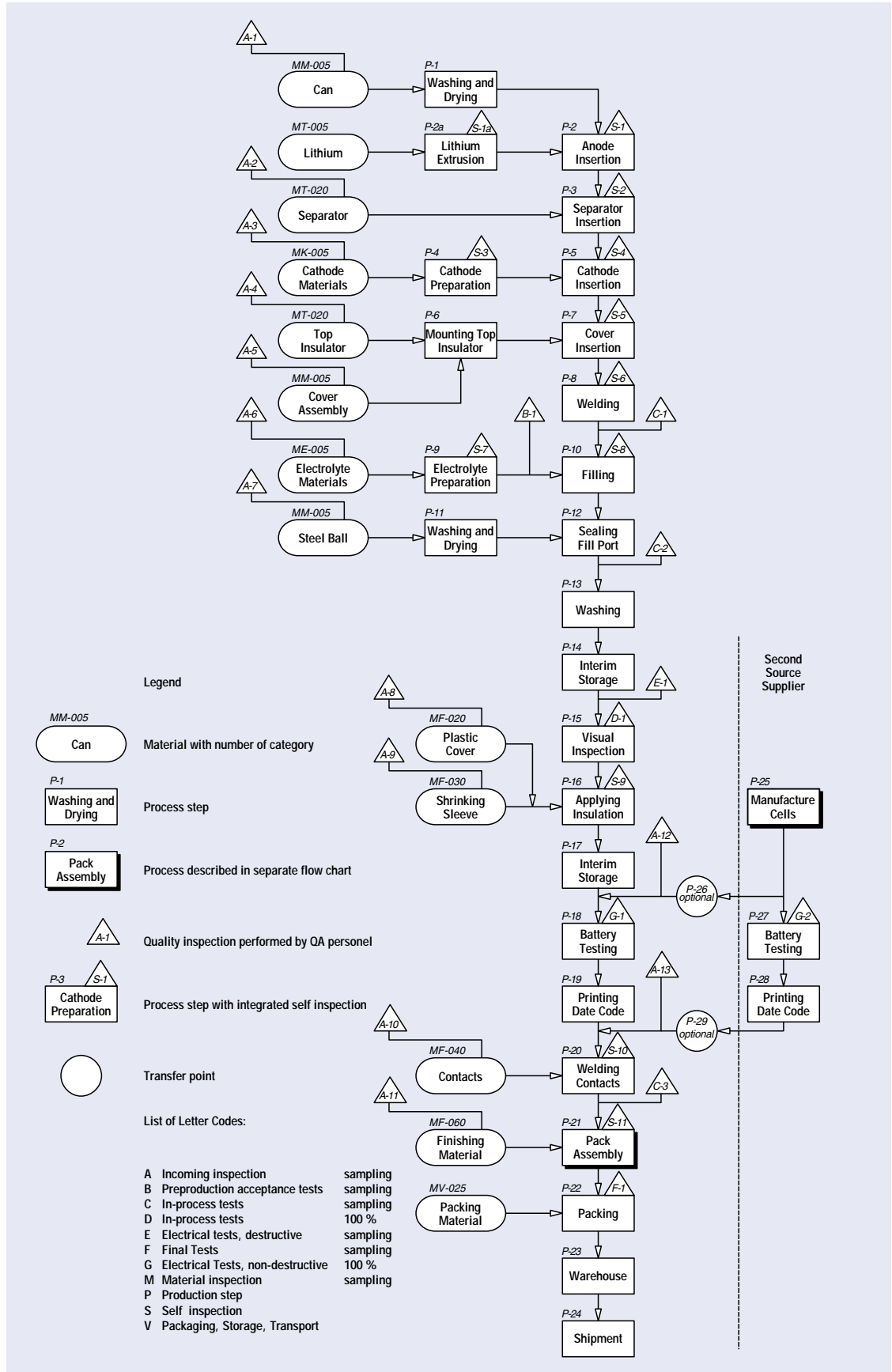

Figure 6-2
 Process flow and inspection plan

6.4 Marking and Traceability

Products manufactured by Sonnenschein Lithium are marked for the purpose of identification and tracing. Typically, the marking includes the battery type number, the lot number as well as the month and year of final inspection. **Figure 6-3** shows an example for battery marking. Any inquiries with respect to the circumstances during manufacture of specific batteries should make reference to the batch number code printed on the battery.

Traceability is effective from the incoming inspection of materials and continues through to final inspection and shipping of the product. The relevant records are kept for a minimum of 15 years.

Figure 6-3
 Battery with type number (T), lot number (L), and date (D) of final inspection. Inquiries should make reference to the batch code.



6.5 Process Flow and Inspection Plan

Sonnenschein Lithium maintains fully documented material specifications, process instructions, and inspection procedures for each of its manufacturing activities.

The stringent requirements for purity of materials, accuracy in component manufacture, and care in assembly and finished product acceptance have made it necessary to establish suitable processes for production and testing and to install highly accurate and reliable instrumentation.

The process flow and inspection plan shown in **figure 6-2** reflects the care that has to be taken in as much a detail as can be given within the frame of this document.

6.6 Reliability

The term reliability refers to the ability of the product to fulfil the specified requirements during its life cycle. As an answer to the particular demands of the market, Sonnenschein Lithium places special emphasis on this aspect of product quality.

A series of long-term tests conducted on a regular basis aims at the acquisition of reliability data under various conditions of storage and use. The criteria for failure are defined according to the most widely spread application needs.

It should be noted here that a battery is not considered a failure when it is depleted after delivery of an amount of capacity that falls into the normal distribution of capacity found under the respective conditions of use. The determination of life time under these conditions is dealt with in chapter 7 under the subject calculation of operating life.

It is a common procedure during reliability testing that the devices under test are subject to accelerated ageing. The results are then transferred into normal operating conditions using calculation methods that have been established previously. It has been pointed out in paragraph 2.5 - storage life and operating life - that equivalent procedures generally cannot be easily established for lithium batteries. It is therefore necessary to confirm all results by real time tests.

Table 6-4 shows a number of representative reliability tests that are being conducted by Sonnenschein Lithium. The table contains only real time data and no extrapolations or other derived data. Failure criteria, results and other relevant information is given in the table.

As a result of these tests it can be stated that the reliability of Sonnenschein Lithium Batteries generally corresponds to failure rates below 200 fit (= 0.175 % per year). It has been shown that the failure rates during storage and memory back-up operation range below 20 fit (= 0.02 % per year). One test demonstrates that it is possible to operate this battery system for more than 10 years at +85 °C.

Type of battery	all	SL-550	SL-360	SL-350	SL-360
Discharge	no	1 MΩ	180 kΩ	1 MΩ	2700 μF
Environmental conditions	+ 25 °C	+ 85 °C	in vehicles	+ 25 °C (3000 pcs) and + 45 °C (3000 pcs)	+ 25 °C (100 pcs) and + 45 °C (100 pcs and glass-house (300 pcs))
Failure criteria	U < 3.66 V	U < 3.6 V	U < 3.5 V	U < 3 V	U < 3.6 V
Sample size	21900	50	500	6000	500
Test duration so far	max. 15.3 yr mean 7.8 yr	max. 10 yr mean 5.5 yr	8.75 yr	90 000 hr	9 yr
Failures	8	0	1	4	0 + 0 + 5
Failure rate	5.3 fit	< 413 fit	28 fit	7.4 fit	126 fit
Reference	82/88	193/88	3/89	40/89	36/91

Table 6-4
 Reliability Data
 A selection of reliability tests conducted by Sonnenschein Lithium
 Results per April 2001. Some tests are being continued.
 fit = failures in time. 1 fit = 1 failure in 10⁹ device-hours

7 Design Aids and Instructions for Use

Sonnenschein Lithium
Technical Brochure

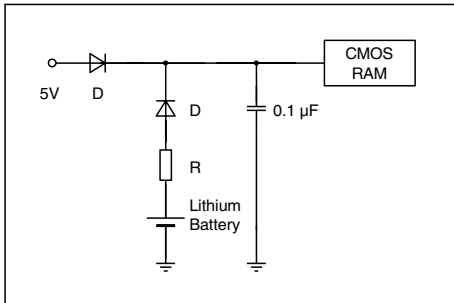

Figure 7-1
Basic memory back-up circuit including safety devices (diodes and resistor) according to case B of the UL recommendations. Case A is obtained if R is replaced with another diode.

The following circuit ideas are provided to assist the circuit designer in utilizing the Sonnenschein Lithium Battery to achieve optimum circuit performance.

Generally, the battery should not be placed close to heat generating components as this may have an effect on its operating life.

Maximum reverse (charging) currents are listed in the Sonnenschein Lithium Product Data Catalogue. To obtain full performance reverse currents should be kept below 10 μ A.

7.1 Back-up circuits

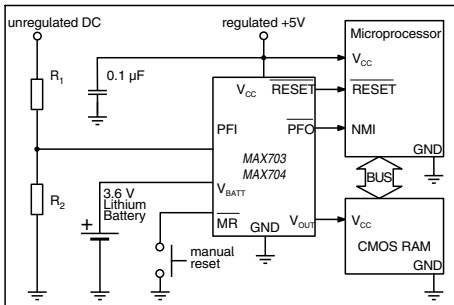

Figure 7-2
Memory back-up circuit employing a controller chip.

Figure 7-1 represents the protection against charging recommended by Underwriters Laboratories for memory back-up circuits (see section 5.2). The diagram reflects case B. Case A is obtained if the resistor R is replaced with another diode.

It is absolutely necessary to provide these safety devices on circuit boards that contain a back-up battery connected in parallel to a power source. The safety devices have to be placed physically as near as possible to the battery. Otherwise unintended shorts between adjacent printed wires or poorly soldered connectors or the like may by-pass the safety devices and allow the power source to pass a reverse (charging) current through the battery.

Figure 7-2 gives an example of a memory back-up circuit employing a controller chip.

Figure 7-3 shows a typical back-up circuit for personal computers. The function of the 10 μ F capacitor is to delay the voltage drop on power failure and thus permit the inverter to deliver the stand-by pulse to the microprocessor at the earliest time.

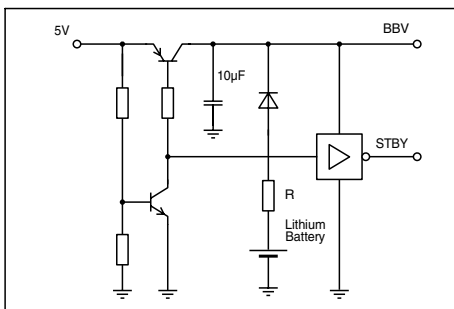

Figure 7-3
Typical back-up circuit for personal computers

Figure 7-4 is the back-up circuit for a real time clock. D_1 , D_2 , D_3 are Germanium diodes, D_4 and D_5 are silicon diodes. The function of D_4 and D_5 is to reduce the normal supply voltage to the oscillator closer to the level of the back-up battery voltage and thus prevent a larger voltage drop under back-up conditions thus increasing the accuracy of the RTC.

Figure 7-5 shows a back-up circuit for continuous and pulse type loads. D_1 and D_2 are silicon diodes while D_3 and D_4 are Germanium diodes or Schottky type MBD701 diodes. This circuit provides back-up to a main power supply with a small continuous load and intermittent higher current pulses. The function of C and D_4 is to stabilize the voltage to the continuous load in case the higher current pulse causes the battery voltage to drop momentarily.

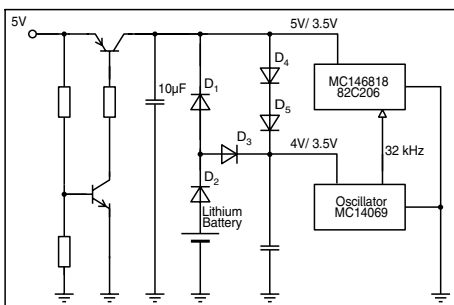

Figure 7-4
Back-up circuit for a real time clock

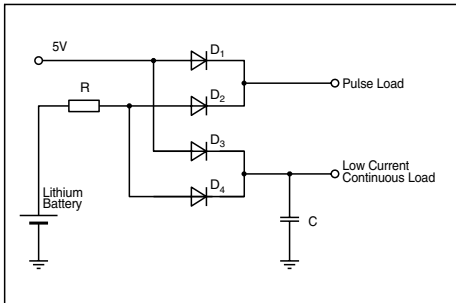

Figure 7-5
 Back-up circuit for continuous and pulse type loads

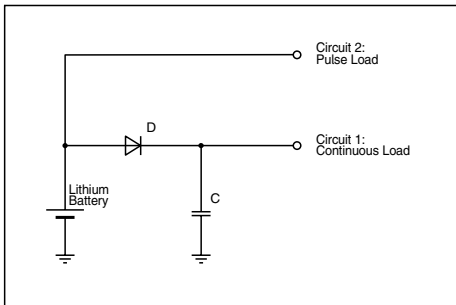

Figure 7-6
 Main battery supply circuit for continuous and pulse type loads. D is a germanium or a Schottky type diode.

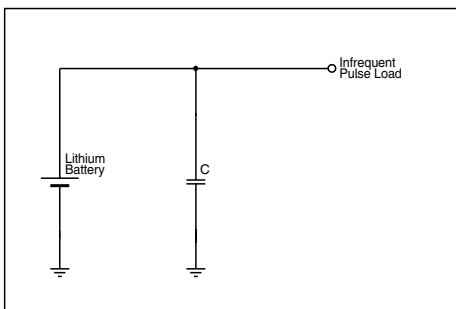

Figure 7-7
 Main battery supply circuit for critical, infrequent pulse loads.

7.2 Capacitor Support

Lithium thionyl chloride batteries can develop internal resistance on prolonged storage or on continuous very low rate operation. This may reduce the amount of capacity available above a certain cut-off voltage. In these situations, a suitable capacitor can increase the available capacity. The following notes are provided to obtain the optimum performance from the batteries. In many cases a lithium thionyl chloride battery with capacitor support will out-perform any other type of battery.

Support of continuous loads

Often the customer's circuitry can be interpreted as consisting of two parts with basically different requirements. One part may consist of the microprocessor and memory. It requires low current and high voltage. The other part may comprise current consumers like transducers, sensors, actuators and the like. It may require pulses of higher current but the voltage is less important.

An advantageous approach to this class of applications is outlined in **Figure 7-6**. During high current pulses, the microprocessor is powered from the capacitor. The battery does not have to supply voltage and current at the same time.

Preferred battery series: SL-700
 Typical service life: 1 ... 3 years
 Type of capacitor: typically electrolytic

Calculation of capacitor size: $C \approx I_1 \times t / U_1$
 with I_1 = current of circuit 1
 t = back-up time
 U_1 = allowed voltage drop for circuit 1

Support of pulse loads

In cases where the voltage requirement of the current consuming part of the circuit is stringent or when the capacity of the battery shall be used beyond the point of increasing impedance, the situation can be adapted to the battery's possibilities by use of a capacitor that is large enough to back-up all current pulses. **Figure 7-7** gives the basic idea of the circuit.

At the first glance this solution may seem to be more expensive than for instance a lithium organic electrolyte battery. However, the useful capacity, the voltage level, and stability of this solution may be so much higher that it becomes less expensive in the long run.

Preferred battery series : SL-300
 Typical service life: 3 ... 10 years
 Type of capacitor: electrolyte or double layer (Super Cap™, Gold Cap™)

Calculation of capacitor size: $C \approx U / R \times t / \Delta U$
 with U = basic voltage
 R = $R_L + R_C$
 R_L = resistance of load circuit
 R_C = internal resistance of capacitor C
 t = back-up time
 ΔU = allowed voltage drop

7.3 Battery Packs

The assembly of multi-cell battery packs requires training and experience. Users that are not qualified accordingly should not attempt to assemble battery packs. Sonnenschein Lithium offers a wide range of customized batteries as well as assistance in developing, engineering, and manufacturing additional ones. Please request the Sonnenschein Lithium questionnaire for battery packs. Additional notes on the protection of lithium battery packs are given on its backside. The following instructions and recommendations serve as a guideline to the qualified battery assembler.

Protective Devices

Battery Packs should be designed so as to prevent unintentional shorting of cells, overheating, and excessive charging and discharging currents. Depending on the conditions of use, protective devices may have to be provided in the battery circuit.

Protection Against Charging

If a battery pack can be used in connection with an independent power source, it should be equipped with blocking diodes D_s in each string of parallel connected cells (see **fig. 7-8**). The leakage current of each diode should not exceed 10 μ A.

Protection Against Overdischarge

If a battery pack can be used in such a way that the discharge current exceeds the maximum reverse current values given in the individual cell data sheets then by-pass diodes D_p should be provided in parallel with each cell in the pack. The effect of a by-pass diode is that current passes through the diode if a cell is discharged. The cell can thus not be overdischarged.

Protection Against Shorting

Appropriate methods and materials should be applied to prevent the occurrence of internal shorts in a battery pack. The insulation material should withstand mechanical and thermal stress. Often the shrinking sleeve of the cell does not fulfil this requirement and needs reinforcement between adjacent cells.

As a protection against external shorting, internal leads should either be selected so as to withstand the expected maximum short-circuit current or placed in such a way that they cannot induce additional short-circuits e.g. when the insulation melts.

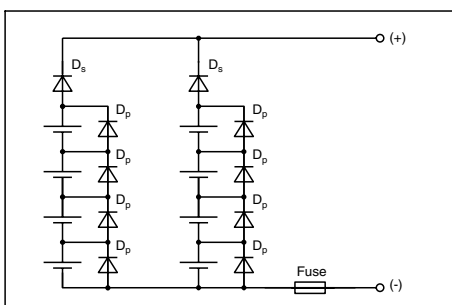

Figure 7-8

Typical multi-cell battery pack with protective devices.

Additional safety devices according to UL recommendations are needed if a battery pack is used as back-up for another power source.

Sonnenschein Lithium cells can be short-circuited without the discharge current rising above a safe value. However, if a battery pack exceeds a certain size, the heat produced during short-circuit cannot be dissipated. In these cases a slow-blow fuse F or a thermal fuse should be provided. This should be done if a current product of 3000 mA (number of cells times maximum continuous cell discharge current) is exceeded.

Selection of Cells

The cells selected for a battery pack should match with respect to type, size and age. Do not mix cells of different technologies or different manufacturers. Marking and type designation should be readable and as required. Cells should be inspected mechanically and electrically before assembly. Inspection criteria are provided upon request.

Assembly Procedure

- Make sure that the component cells are insulated one from the other.
- Position and insulate electrical leads, links and contacts in such a way that short-circuits are prevented.
- Only interconnect the cells by soldering or spot welding to the flat strip (tag) terminations.
- Keep the soldering time as short as possible, below 10 seconds.
- With the larger cell sizes, particularly with the C, D and DD sizes, the preferred cell orientation in a battery pack is upright.
- Do not attempt to solder or spot-weld directly to the cell case. This can result in gross overheating and consequent hazard. Cells are supplied with various terminations for this purpose.
- Use polarized (keyed) battery connectors or at least be sure to properly identify the polarity and protect the ends of battery leads.
- Properly mark the battery pack (type / nominal voltage / date code) and affix appropriate safety labelling.
- Do not wear conductive jewellery when assembling battery packs or connecting cells to equipment.
- Always wear eye protection when assembling battery packs or connecting cells to equipment.
- Perform spot welding or soldering behind safety shields.
- Only use suitably insulated tools.
- Use encapsulating, insulating and similar battery pack materials at the minimum required levels, so as to limit the build-up of heat within the pack.
- When molding, make sure not to inhibit proper operation of any safety vents.
- Do not use flammable materials.
- Verify compliance of your battery pack design with the applicable shipping and handling requirements, by performing corresponding shock and vibration tests.

7.4 Lithium Battery Questionnaire

A lithium battery questionnaire is in the Product Data Catalogue. It contains the details that Sonnenschein Lithium engineers need to provide their customers with the most appropriate solution to their application. It

forms the basis for calculation of the available battery capacity determining the useful battery life.

7.5 Application Proposal and Capacity Calculation

Sonnenschein Lithium Product Data Catalogues and other data sheets contain typical battery capacities for different load and ambient conditions. In most applications, however, these are not constant throughout the battery life. As the effects of conditions changing during battery life cannot be predicted from the data sheets it becomes necessary in most cases to calculate the expected battery using a procedure like the one described below. As a result, an application proposal is obtained that forms part of the technical quotation.

- Determine the general conditions

For this purpose, customer name, application field, project name, project size, time schedule etc. should be entered into the lithium battery questionnaire.

- Calculate current consumption

The current profile is compiled from the basic or quiescent current and the pulse current contributions. These are determined by the amplitude, pulse duration and duty cycle (on/off periods).

- Consider customer requirements

Requirements with respect to cut-off voltage and operating life should be known as they have influence on the proposal.

- Select battery type

A battery type will be selected based on the customer's requirements and conditions of use.

- Calculate battery life
 - compile the temperature profile
 - enter the average current corresponding to this temperature
 - enter the battery capacity corresponding to this temperature from the "Available Capacity" diagrams of the data sheets.
 - calculate the availability factor which accounts for the effect of long-term operation as well as the effect of pulse amplitudes
 - calculate the electrical operating life
 - calculate the system life which takes into account those effects that are independent from the electrical processes like e.g. ageing of the isolation system.
 - calculate the resulting battery life which is basically the minimum of the electrical operating life and the system life.
- Add remarks

The proposal may contain additional hints. These may include depassivation procedures, capacitor support and additional remarks depending on the circumstances and the customer's requirements.

- Liability

Application proposals will usually be concluded by a general liability statement.

7.6 Depassivation

Inorganic lithium batteries may under certain circumstances need depassivation before they operate satisfactorily. These depend on the type of battery, storage conditions, current profile, and voltage requirements. The effect is caused by the protective layer which is described in paragraph 3.3. Effects on performance are described in paragraph 2.2.

There exist several depassivation methods, some of which may be carried out even without being noticed as a depassivation procedure.

If batteries are not older than 6 to 12 months before mounting, the temperature cycle and temporary short-circuit during wave soldering may be sufficient for depassivation.

A method that can be applied during manual handling of small numbers of batteries is a short-circuit of several seconds. The method will momentarily break up the protective layer and increase its conductivity by several orders of magnitude. Surprisingly, the same effect may be obtained by shock freezing the battery within the recommended storage temperature range.

A depassivation method that has been suggested for large numbers of batteries in a highly automated assembly line for instrumentation equipped with D-size batteries, is passing a current of 60 mA for 30 s through a resistor of 56 Ω . For other battery sizes the current should be adjusted to approximately 2 mA/cm². The method may be refined by adjusting the current amplitude so that the battery voltage drops to one half of its open circuit value, or by applying a pulse load, or by a combination of both.

If current capability is needed only several weeks or more after installation of the battery it is likely that the quiescent current will depassivate the battery sufficiently so that no depassivation needs to be carried out.

8 Storage, Transport, Handling, and Disposal

8.1 General Precautions

Sonnenschein Lithium Batteries are primary power sources with high energy content. They are designed to represent the highest possible degree of safety. They may, however, present a potential hazard if they are abused electrically or mechanically. This is in most circumstances associated with the generation of excessive heat. The internal pressure may cause the cell case to rupture.

Thus the following basic precautions should be observed when handling and using Sonnenschein Lithium Batteries:

Caution

- Do not short-circuit
- Do not recharge
- Do not overdischarge
- Do not incinerate
- Do not expose to temperatures beyond the specified temperature range
- Do not crush or puncture
- Do not open cells, do not disassemble battery packs
- Do not expose contents to water
- Do not connect with false polarity
- Do not weld or solder to the battery's body

For general safety considerations please refer to chapter 4. Additional precautions for the assembly of battery packs are given in paragraph 7.3.

8.2 Storage

General Conditions

Batteries should be stored in rooms with generally low temperature and low humidity levels. While it is not essential that these storage areas be temperature and humidity controlled, temperatures should generally be kept below 35 °C and storage areas should be well ventilated.

Storage temperatures above 75 °C should be avoided.

Insulation

Lithium batteries should be stored in their original packaging materials. This will eliminate unintentional shorting.

Do not store batteries in conductive anti-static bags or foam unless the resistivity of the material exceeds 1 MΩ. Batteries should not be placed on or covered with metallic or otherwise conductive material.

Fire protection

Batteries should be stored away from any flammable material in the storage area.

Fire extinguishers for metal fire (class D) are preferred. Do not attempt to extinguish fires with small amounts of water, sand, or with carbon dioxide extinguishers.

A Technical Notice with further recommendations is available upon request.

8.3 Transport Regulations

Lithium Batteries are generally classified as dangerous goods according to UN 3090 (lithium batteries) and UN 3091 (lithium batteries contained in equipment or packed with equipment). The table on the next page gives a brief summary of the regulations.

However, most Sonnenschein Lithium Batteries are not subject to the transport regulations because they meet the provisions listed hereafter:

- Cells contain no more than 0.5 g of lithium or lithium alloy.
- Battery packs contain an aggregate quantity of no more than 1 g of lithium or lithium alloy.
- Sonnenschein Lithium Batteries, besides SL-790, contain not more than 5 g of lithium per cell and not more than 25 g per battery pack and have passed the tests required by the UN manual of tests and criteria. Therefore, they are not subject to the regulations, provided the following general rules are observed:
 - Each cell is hermetically sealed.
 - Batteries are separated from each other in the package so as to prevent shorting.
 - Battery packs are packed in strong outside packaging (except when installed in electronic devices).

Transport regulations for lithium batteries subject to class 9					
UN-No.	Limitations and Instructions	Passenger aircraft IATA DGR	Cargo aircraft IATA DGR	Road/ Railway transport ADR/RID	Sea transport IMDG Code
Lithium batteries					
3090	Maximum amount of lithium per cell	12 g	12 g	12 g	12 g
	Maximum amount of lithium per battery pack	500 g	500 g	500 g	500 g
	Maximum amount of lithium per package	–	–	–	500 g
	Maximum gross weight per package	5 kg	35 kg	400 kg	250 kg
	Packing group	II	II	II	II
	Packing instruction	903	903	2906	9033–9033b
	Marking	Class 9 label	Class 9 label Handling Label For Cargo Aircraft Only	Class 9 label	Class 9 label
Lithium batteries contained in equipment / packed with equipment					
3091	Maximum amount of lithium per cell	12 g	12 g	12 g	12 g
	Maximum amount of lithium per battery pack	500 g	500 g	500 g	500 g
	Maximum amount of batteries per piece of equipment	5 kg / –	5 kg / –	– / –	10 pieces
	Maximum gross weight per package	– / 5 kg	– / 35 kg	400 kg	250 kg
	Packing group	II	II	II	II
	Packing instruction	903, 912 / 918	903, 912 / 918	2906	9033–9033b
	Marking	Class 9 label	Class 9 label	Class 9 label	Class 9 label

Table

Transport regulations for Sonnenschein Lithium Batteries.

These regulations apply to type SL-790 (lithium content 10 g) and to battery packs containing more than 1 cell. Battery packs need to be tested according to the UN manual of tests and criteria in order to be attributed to class 9.

It is necessary to refer to the listed regulations and instructions for detailed information. They are reviewed on a regular basis. The table is based on the 2000 revisions.

The applicable documents are:

ADR: European Agreement concerning the International Carriage of Dangerous Goods by Road,

IATA DGR: International Air Transport Association, Dangerous Goods Regulations

ICAO: International Civil Aviation Organization, Technical Instructions for the Safe Transport of Dangerous Goods by Air.

IMDG Code: International Maritime Dangerous Goods Code

RID: International Statutory Order on the Conveyance of Dangerous Goods by Rail

UN: United Nations Recommendations on the Transport of Dangerous Goods

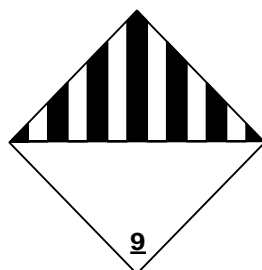

Class 9 label,
reduced size,
black on white



Handling Label for
Cargo Aircraft Only,
reduced size,
black on orange

8.4 Mounting

General

In most cases, Sonnenschein Lithium Batteries are soldered to the PC-board. Replaceable batteries usually are equipped with connectors and hook and loop tapes to ensure quick and safe mounting. Other mounting techniques may include hot melt glue or plastic tapes to secure the battery to the PC-board. Solder pins and tags usually are not suitable as battery holders, especially with the cells of size C and larger.

Sonnenschein Lithium Batteries comply with IEC standard 68-2-21 and ESA specification PSS-01-708. This means that solder pins and tags can withstand a tensile force of 10 N in the direction of their axis. Pins can be bent with an inside radius of 0.8 mm at a minimum distance of 2.5 mm. Alternative geometries should be used when smaller distances are needed (Fig. 8-3).

When the battery is mounted on the PC-board, it should not make contact to the conductive mat that is used to eliminate static electricity as this may cause a discharge circuit and lead to premature depletion.

Hand Soldering

Use only batteries that have been provided by Sonnenschein Lithium with solder tags or wire leads, when it is required to make soldered connections to them.

Caution

- Do not attempt to solder directly to the cell case or terminal.
- Keep the soldering time as short as possible, below 10 seconds.
- Use appropriate protection during pretinning. Batteries must not be dropped in tin baths.

Wave Soldering

The Sonnenschein Lithium Battery is a safe power source. It has moderate impedance and, when operating at temperatures up to 75°C, it can withstand a continuous short-circuit without any safety problems, the battery will not explode, crack or leak. It is therefore, in principle, suitable for wave soldering. However, the following recommendations should be observed:

Sonnenschein Lithium flat cells are provided with nickel pins and may be wave soldered.

Sonnenschein Lithium bobbin type cells can be provided with axial wire leads or with nickel solder tags. The small cells may be wave soldered. The big cells should be hand soldered for reasons of safety.

If a battery is dropped into the solder bath, or if it is held above the bath for a long period, it might rupture, due to overheating and consequent melting of the lithium metal.

Caution

- Secure the battery to the printed circuit board before introducing it into the wave soldering process (including pre-heating and drying).
- Do not overheat. Refer to **table 8-4** for recommendations.
- Provide a cover over the soldering zone when lithium cells are being wave soldered.
- Do not use reflow soldering when mounting cells.

Cleaning processes are not standardized. Therefore compatibility may have to be established case by case. Water should not get trapped underneath the jacket. Organic solvents may have an effect on the readability of markings or on the softening agent of the jacket. Please contact Sonnenschein Lithium for recommendation of approved processes.

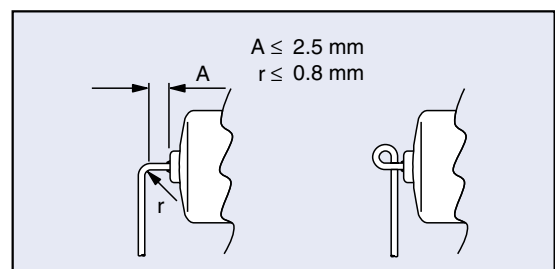

Figure 8-3
Minimum bend of pins, alternative geometry

Operation	Temperature	Time
Preheat (wave)	up to 140°C	up to 180 s
Wave	up to 280°C	up to 10 s
Cleaning	up to 85°C	
Drying	up to 100°C	up to 120 s

Table 8-4
Recommendations for wave soldering

8.5 Disposal

The disposal or recycling of batteries is regulated by each European country. In each country, the manufacturers, importers and users are responsible for the proper disposal.

The European Community (EC) has issued two directives, 91/157/EEC and 93/86/EEC. These directives are implemented by each member country of the EC independently and in a different way.

In accordance with these directives, Sonnenschein Lithium Batteries do not contain dangerous substances. The reaction products are inorganic and do not represent environmental risks once the decomposition process has terminated.

For batteries bought from Sonnenschein Lithium, a disposal service is offered upon customer request.

A Technical Notice with further recommendations is available upon request.

9 Glossary

The intention of this glossary is to explain certain technical terms and their use in this brochure. The definitions are not necessarily identical to terms that are standardized in a different context.

Active Current Level

Discharge current of approximately 2 $\mu\text{A}/\text{cm}^2$ of anode surface. This current level is sufficient to prevent passivation of a battery under most circumstances.

Active Material

The material in the electrodes of a battery which takes part in the electrochemical reactions of charge or discharge.

Anode

The electrode in an electrochemical cell where oxidation takes place. In primary batteries it is always the negative electrode. In lithium batteries, the active material of the anode is lithium.

Anode Surface Area

The anode surface area provides an indication of the current capability and design of a battery.

Available Capacity

The total capacity that will be obtained from a battery at defined discharge rates and other specified operating conditions. In the Sonnenschein Lithium Product Data Catalogue, the diagrams showing available capacity give an indication of the confidence range of expected capacities at different current levels depending on ambient temperature.

Battery

An electrochemical power source comprising one or more cells. Cells can be electrically connected in a series and/or parallel assembly. →Battery Pack

Battery Pack

An assembly of electrochemical cells electrically interconnected in an appropriate series/parallel arrangement to provide the required operating voltage and current level. A battery pack most often includes an additional jacket and wires/connectors. In this documentation, the term "battery" is used instead of battery pack unless exclusion of a single cell without the cable and connector is intended.

Bobbin

A cylindrical electrode (usually the positive) pressed from a mixture of the active material, a conductive material, such as carbon black, the electrolyte and/or binder with a centrally located conductive rod or other means for a current collector.

Capacity

The total quantity of electricity in ampere-hours (Ah) that can be withdrawn from a fully charged battery under specified conditions of discharge. →Available capacity, Nominal capacity.

Capacity Retention

The fraction of the full capacity available from a battery under specified conditions of discharge after it has been stored for a period of time.

Cathode

The electrode in an electrochemical cell where reduction takes place. In primary batteries it is always the positive electrode.

Catholyte

Coined word that is used for the active cathodic material of liquid cathode systems indicating that it is contained in the electrolyte.

Cell

The basic electrochemical unit used to generate or store electrical energy. In this documentation, the term "cell" is used only to emphasize this basic unit. Otherwise the term "battery" is used.

Closed-Circuit Voltage (CCV)

The voltage of a battery during discharge.

Cut-off Voltage

Minimum voltage level when a battery is considered no longer usable in a given application.

Current

→Drain

Current Collector

An inert part of high electrical conductivity used to conduct current from or to an electrode during discharge.

Current Density

The current per unit electrode surface area.

Depassivation

A procedure that prepares a battery for operation when otherwise initial →passivation would cause a voltage drop below the cut-off voltage.

Depth of Discharge (DOD)

The ratio of the capacity delivered by a battery at time t during discharge to its total capacity available under specified conditions.

Diffusion

The movement of species under the influence of a concentration gradient.

Discharge

The conversion of the chemical energy of a battery into electrical energy and withdrawal of the electrical energy into a load.

Discharge Efficiency (Yield)

Percentage of the nominal capacity delivered during a given duty.

Discharge Rate

The rate, usually expressed in amperes, at which electrical current is taken from the battery.

DOD

→Depth of discharge

Drain

Discharge current from a battery. Expressed in amperes (A). With respect to Sonnenschein Lithium Batteries, the following regimes are distinguished:

High Current Drain

Duration of discharge less than 20 hours

Medium Current Drain

Duration of discharge between 20 and 2000 hours

Low Current Drain

Duration of discharge greater than 2000 hours

Duty Cycle

With respect to periodic current pulses, the term is used to denote the ratio between on- and off-time.

Efficiency

→Discharge efficiency

Electrode

A part of the cell where electrochemical processes take place. Anode or cathode.

Electrolyte

The medium which provides the ion transport mechanism between the positive and negative electrodes of a cell.

- End Voltage**
→Cut-off voltage
- Energy**
The energy of a battery is obtained from the product of capacity and operating voltage. It is measured in Watt-hours (Wh).
- Energy Density**
The ratio of the energy available from a battery to its volume (Wh/dm³).
- Energy, specific**
The ratio of the energy available from a battery to its weight (Wh/kg).
- Flat Construction**
A cell design in which the electrodes are arranged in layers.
- Forced Discharge**
Discharging a cell or battery, with an external battery or other power source, below zero Volts into voltage reversal.
- Internal Resistance**
Internal resistance is defined as voltage drop divided by current change: $R_i = \Delta U / \Delta I$. The value changes during discharge. See figure 2-13.
- Jelly Roll**
→Spirally wound construction
- Liquid Cathode**
Thionyl chloride is an example for a liquid cathode.
→Catholyte
- Maximum Continuous Discharge Current**
The highest current at which a battery will still provide more than 15% of its nominal capacity. This value is given to help decide on possible applications.
- Maximum Pulse Current**
It is an indication of the pulse current capability. The values given in the Sonnenschein Lithium Product Data Catalogue refer to 6 pulses of 0.5 s each per hour at 25 °C at a current level of approximately 10 mA/cm².
- Midpoint Voltage**
The voltage of a battery midway in the discharge between the fully charged state and the end voltage.
- Nominal Capacity**
The average capacity of a battery type under favourable conditions (load, ambient temperature). In the diagrams of the Sonnenschein Lithium Product Data Catalogue showing "Available Capacity", the nominal capacity is marked with a dot to give an idea of the actual capacity values that can be expected under practical conditions.
- Nominal Voltage**
The nominal voltage characterizes the electrochemical system. It is observed during discharge at low current drain levels.
- Open Circuit Voltage (OCV)**
The voltage between the terminals of a cell or voltage when the circuit is open (off-load condition).
- Operating Voltage**
The average voltage during discharge at a given load and temperature over the entire duration of discharge until the end voltage is reached.
- Overdischarge**
→Forced discharge
- Parallel Assembly**
A battery assembly where all cell terminals of equal polarity are connected together. Capacity and current capability are multiplied. Voltage is invariant.
→series assembly
- Passivation**
The phenomenon by which a metal, although in conditions of thermodynamic instability, is protected due to the formation of a surface layer.
- Primary Battery**
Non-rechargeable battery. →secondary battery
- Positive Temperature Coefficient Resistor (PTC)**
Equivalent to a resettable fuse connected in series with a battery pack. It undergoes a large and abrupt increase in resistance at a predetermined current and temperature.
- Safety Vent**
A normally sealed mechanism which allows for the controlled escape of gases from within a cell.
- Secondary Battery**
Rechargeable battery. →primary battery
- Self-Discharge**
Loss of useful energy at rest or during discharge because of internal chemical reactions.
- Separator**
An ionically-permeable but electronically non-conductive material installed between the cell anode and cathode. It prevents any electronic contact between them.
- Series Assembly**
A battery assembly in which the positive terminal of one cell is connected to the negative terminal of the next cell and so forth. Voltage is multiplied, capacity and current capability are invariant.
→parallel assembly
- Service Life**
The period of useful life of a primary battery before a predetermined end voltage is reached.
- Shelf Life**
The duration of storage under specified conditions at the end of which a battery still retains the ability to deliver a specified performance.
- Short-Circuit Current (SCC)**
The initial value of the current obtained from a battery in a circuit of negligible resistance. In a broader sense it is the current evolving during short-circuit of a battery.
- Specific Energy**
→Energy, specific
- Spirally Wound Construction**
Refers to the arrangement of electrodes in a cylindrical cell. It is made by winding the electrodes and separator like a jelly-roll. As opposed to bobbin construction.
- Stand-by Battery**
A battery designed to sustain certain functions of a circuit in the event of a main power failure.
- Storage Life**
→Shelf Life
- Transient Minimum Voltage (TMV)**
The minimum voltage experienced during the voltage delay when a battery is first connected to a load.
- Vent**
→Safety vent
- Voltage Delay**
Time delay for a battery to recover to the required output voltage after being connected to a load.

Contents

Sonnenschein Lithium
Technical Brochure

Paragraph	Title	Page
1	Basic Information	2
1.1	Sonnenschein Lithium	2
1.2	The Sonnenschein Lithium Battery	2
1.3	Comparison to Other Systems	2
1.4	Customer Benefits	3
1.5	Applications	3
2	Performance	4
2.1	General	4
2.2	Voltage Response	4
2.3	Discharge Current and Capacity	6
2.4	Current Pulses	6
2.5	Storage Life and Operating Life	7
2.6	Orientation	8
2.7	Temperature Dependence	8
2.8	Environmental Conditions	9
2.9	Internal Resistance	9
2.10	Features and Attributes of the Basic Series	10
3	Cell Design	10
3.1	Cell Components and Materials	10
3.2	Mechanical Design	10
3.3	Chemical Reaction and Protective Layer	12
4	Safety	14
4.1	General	14
4.2	Intended use tests	14
4.3	Reasonably foreseeable misuse tests	14
4.4	Information for safety	16
5	Conformity with Standards	17
5.1	Underwriters Laboratories (UL)	17
5.2	Explosive atmospheres	18
5.3	Military Standards	18
6	Quality and Reliability	19
6.1	Corporate Policy	19
6.2	Certified Management System	19
6.3	Calibration and Inspection Equipment	19
6.4	Marking and Traceability	21
6.5	Process Flow and Inspection Plan	21
6.6	Reliability	21
7	Design Aids and Instructions for Use	22
7.1	Back-up Circuits	22
7.2	Capacitor Support	23
7.3	Battery Packs	24
7.4	Lithium Battery Questionnaire	24
7.5	Application Proposal and Capacity Calculation	25
7.6	Depassivation	25
8	Storage, Transport, Handling, and Disposal	26
8.1	General Precautions	26
8.2	Storage	26
8.3	Transport Regulations	26
8.4	Mounting	28
8.5	Disposal	28
9	Glossary	29



ELEKTRO.TEC GmbH
Eichborndamm 129-139
D-13403 Berlin - Germany
Tel.: +49(0)30/4111024 Fax: +49(0)30/4111025
E-Mail: info@lithium-batterie.de
Internet: <http://www.lithium-batterie.de>